

H A S S E L B L A D



User Manual

503CW/503CWD/CFV/CFVII/CFV-39/CFV-50

Version 10

Welcome to Hasselblad

503CW

503CWD

CFV



C O N T E N T S

Introduction	4
---------------------	----------

503cw

1 General information	6	Removing the lens	14	Attaching and removing	19, 20
Parts & components	7	Exposure	14	Magazine status indicator	20
2 Camera body	9	Warning mark	14	Film loading	20
Front protective cover	10	Exposure values	14	Film tab holder	21
Rear cover MultiControl	10	Interlocked shutter speed /aperture	14	Film plane position	21
Opening the focusing hood	10	Focusing and depth of field	14	Double exposure	21
Built-in magnifier	10	Depth of field preview	15	Flash / strobe with film	21
Focusing screen and viewfinder image	10	Pre-release and cable release	15	Setting film speed for TTL/OTF flash	22
Closing the focusing hood	10	Flash /strobe synchronization	15	Viewfinder indicator	22
Winding crank	11	4 The Viewfinder System	16	Flash adaptor	22
Accessory rail	11	Changing the focusing hood or viewfinder	17	Infrared film	22
Strap attachment and removal	11	Changing the magnifier	17	6 Accessories	24
3 Lenses	12	Changing the focusing screen	17	Rear cover MultiControl	25
Shutter speed and aperture	13	5 Film Magazines	18	Technical Specifications	27
Attaching the lens	13	Parts & components	19	Troubleshooting	27

CFV

1 Overview	28	3 Previews	51	7 Settings	72
Introduction	29	Preview modes	52	User interface	74
Before you start	30	4 Batches & browsing	55	Camera	75
Computer system requirements	31	Batches	56	About	82
Warnings and restrictions	31	Current batch	56	Custom options	83
Parts, components & control panel buttons	32	Creating a new batch	57	8 Cleaning	85
Battery	34	Browse	57	9 Appendix	87
Attaching and removing	36	Basic image browsing	58	Technical specifications	88
On/off button	36	Navigating batches	59	Equipment care and service	89
Battery warning	36	Browsing batches	60	Further reading	89
Flash/strobe	37	Thumbnail views	60		
Overview menu/navigation/settings	39	Viewing modes	60		
Overview menu structure	40	5 IAA	61		
Overview storage/settings	41	Using Instant Approval Architecture	62		
2 Getting started	42	Standard Instant Approval workflow	62		
File storage	43	Default approval status	64		
ImageBank-II	44	Browsing by approval status	65		
CF cards	45	6 Delete, Format, Copy	66		
Tethered to a computer	46	Deleting single images	67		
Initial settings	47	Deleting by Approval status	68		
ISO	48	Deleting several images from a batch	69		
White balance	48	Deleting several images from a CF card	70		
Media	49	Copy	71		
Browse	50	Format	71		
Shortcuts	50				

About this manual

This manual describes how to work with Hasselblad 503CW/503CWD model cameras and Hasselblad CFV digital backs. CFV-39 and the CFV-50 digital backs are the currently available models and are therefore reflected in this manual together with the current firmware update (as of 09/2011). Please refer to previous manuals for details concerning older firmware versions.

The manual explains specific practical aspects of camera operation and control, the menu system and suchlike details regarding these products. It is assumed that reasonable levels of general analogue and digital photographic knowledge as well as computer skills are already acquired, so these are not dealt with here.



The Hasselblad 503CW is an extremely popular model from the 500 series. Soon after it was launched it became the workhorse for so many photographers, professional and amateur alike. It is an all-rounder, being as easy to use on location as in the studio.

There are many who prefer a more traditional design of camera while wishing to exploit the latest in technology and that is where the Hasselblad 503 CWD comes in. It offers the best from both worlds, mechanical and electronic. And for those who already own V-System cameras and don't want to change, the CFV offers the chance to go digital in the most convenient and economical manner.

Hasselblad is the choice of the world's leading photographers, and the name is synonymous with compatibility, reliability and image quality, reaching beyond the ends of the earth and into space. Congratulations, therefore, on a wise choice.

The System

The Hasselblad V-System is the most comprehensive medium-format photographic system in the world. It offers magazines for different image formats and films, viewfinders with or without exposure metering capabilities, a number of focusing screens plus a range of lenses..

The Camera

The completely mechanical camera body boasts a one-piece aluminium alloy construction to meet professional demands. The Winder CW, specifically designed for the 503CW models, provides fast sequential photography and various choices of remote control, including IR. Altogether, a winning combination for professional or dedicated amateur use.

The Lenses

You have access to the whole range of Hasselblad 'C' series lenses both old and new. Lenses are specially manufactured for Hasselblad by Carl Zeiss of Germany – the indisputable leader in camera optics. The Hasselblad specifications of these lenses exceed the demands made by digital capture to ensure the optimum in performance whatever the chosen medium. The integral shutter feature combines with the TTL/OTF facility to provide tremendous flash freedom.

The CFV digital backs

The digital backs are custom built to fit the design and functionality of Hasselblad V-System cameras. However, they can also fit onto view cameras using the V-System interface plate for mechanical attachment and flash sync connection to trigger the digital capture for optimum compatibility and economy. They provide both cable free and computer tethered options to suit all types of work. The units offer an ultra high level of integration, two capture formats, image quality and flexibility to the specialist professional photographer or high-end amateur user.

"Instant" user interface

The 503CWD and CFV are operated with a straightforward user interface with a series of "instant" one-button-click operations including: instant capture, instant browse, instant approval, instant zoom, and instant image info.

Three modes of operation and storage

Optimum portability and image storage are critical for the professional photographer. The 503CWD and CFV offer a choice of portable CF card storage or tethered operation with extended, special capture controls. With these operating and storage options, the photographer is able to select a mode to suit the nature of the work at hand, whether in the studio or on location.



Phocus

Phocus offers an image processing workflow with the highest degree of control. In tethered operation, tools like overlay masking help bring productivity to advanced set composition. Phocus processes the raw 3FR files generated by the Hasselblad 503CWD and CFV. It runs natively on both Macintosh and Windows platforms and is licensed to allow you to provide free copies for all your co-workers and production partners.

3FR format

In order to incorporate the unique HNCS feature we have developed a custom Hasselblad raw file format called 3F RAW (3FR). The new 3FR file format is designed to ensure that images captured on Hasselblad digital products are quickly, effectively and safely stored on the available media. This file format includes lossless image compression, which reduces the required storage space by 33%. The 3FR file defines the colors in the Hasselblad RGB color space with its out-of-the-box quality, and used in conjunction with Phocus it removes both the need for experimenting with different color profiles to obtain optimal colors and the need for selective color corrections.

Unique Hasselblad Natural Color Solution

In the past, color management solutions have imposed limitations on professional digital photographers, because of the need to choose a specific color profile to suit a specific job in order to capture various skin tones, metals, fabrics, flowers, etc. Hasselblad has helped solve this dilemma, with the development of a single powerful color profile to be used with its Phocus imaging software. Working with the new Hasselblad Natural Color Solution (HNCS) enables you to produce outstanding and reliable out-of-the-box colors, with skin tones, specific product colors and other difficult tones reproduced easily and effectively.



DAC

Images captured with a CFV and Carl Zeiss C series lenses can claim the tremendous benefits of DAC. This feature, incorporated in Phocus, makes lens model-specific corrections to ensure the ultimate image quality.

Instant Approval Architecture

Limitless digital image capture loses some of its potential if the photographer cannot quickly review and select the best images to present to the client. Building on the success of its Audio Exposure Feedback technology, Hasselblad has created Instant Approval Architecture (IAA), an enhanced set of feedback tools, designed to liberate the photographer to focus on the shoot rather than the selection process. IAA triggers audible and visual signals for each image captured, notifying the photographer immediately of its classification status. The information is recorded both in the file and in the file name, providing a quick and easy way to classify and select images, in the field or in the lab. The Hasselblad Instant Approval Architecture brings automated image classification into your digital workflow from the split-second of capture. IAA is a Hasselblad trademark and Hasselblad has a patent pending on the invention. Large enhanced display screens on the new Hasselblad products provide a realistic, high quality and perfect contrast image view, even in bright sunlight, to allow instant on-site image approval.



Your new Hasselblad camera provides access to the Hasselblad potential. The realization of this potential is only dependant upon your skill, care and judgement as a photographer. We wish you great success and welcome you to Hasselblad, the most comprehensive medium-format system in the world.

The supreme Hasselblad potential is there, it's up to you to exploit it!

503 cw

1

General Information



Photo: Joao Carlos / Hasselblad Masters

Parts & Components

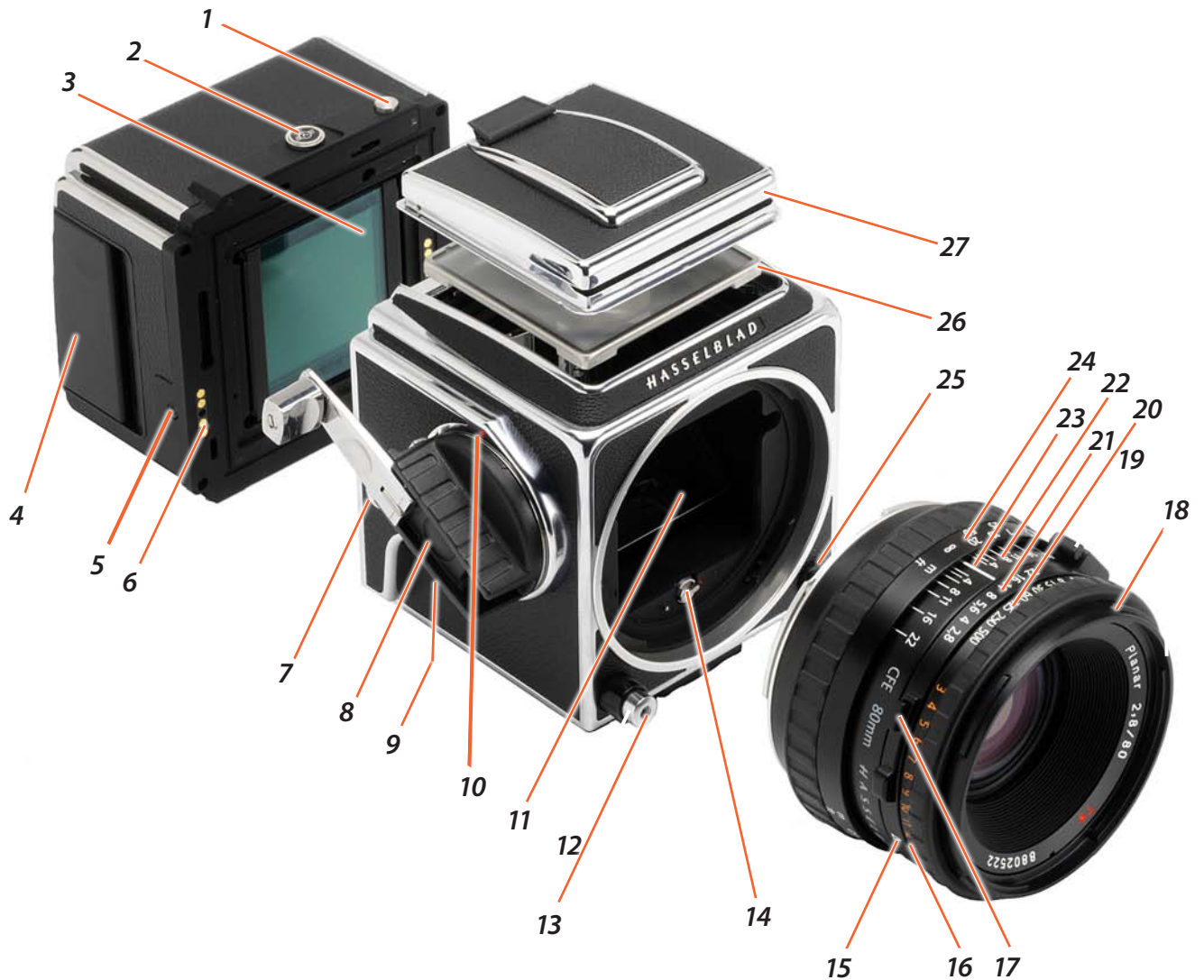

1. Lock safety button
2. Lock button
3. Sensor (covered by glass IR filter)
4. CF card cover
5. Sync socket (for use with Winder CW and EL-type cameras)
6. Databus contacts
7. Strap lug
8. Winding crank
9. Pre-release button
10. Winding crank index
11. Viewfinder mirror
12. Shutter release button
13. Threaded cable release socket

14. Drive shaft
15. Exposure value index
16. Exposure value scale
17. Shutter speed and aperture interlock button
18. External and internal lens accessory mount
19. PC flash/strobe terminal
20. Shutter speed ring
21. Aperture ring and scale
22. Depth-of-field scale
23. Central lens index
24. Focusing ring and scale
25. Lens release button
26. Focusing screen: Acute-Matte D screen
27. Focusing hood

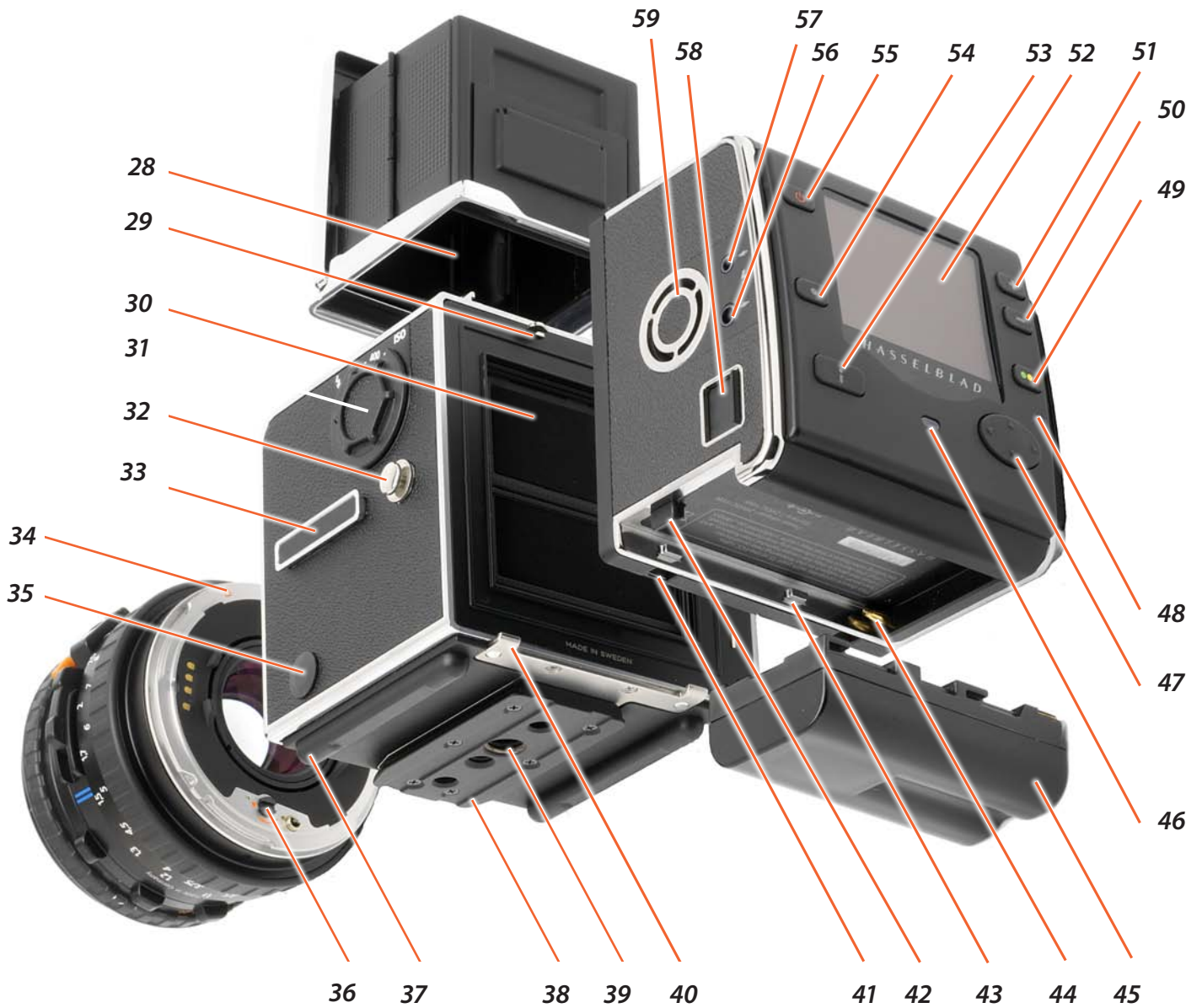

28. Focusing hood magnifier

29. Magazine hook

30. Auxiliary shutter

31. Film speed selector

32. Strap lug

33. Accessory rail

34. Lens locating index

35. Dedicated flash/strobe connector

36. Lens drive shaft

37. Camera support

38. Quick-coupling plate

39. Tripod threads, 1/4" & 3/8"

40. Digital back / magazine supports

41. Digital back support slots

42. Battery release catch

43. Battery support lugs

44. Battery contacts

45. Battery (not supplied)

46. Ready light indicator

47. Navigation button

48. Busy light indicator

49. Instant Approval button

50. Zoom out / Value change button

51. Zoom in / Value change button

52. Display

53. Display button

54. Menu button

55. ON / OFF button

56. Flash sync OUT terminal

57. Flash sync IN terminal

58. Firewire 800 socket

59. Ventilator

503 cw

2

Camera Body

This section describes the basic operations. Follow the instructions step-by-step to avoid damaging the equipment. Check that the winding crank on the right hand side of the camera is locked thus ensuring that the camera is fully wound. If the crank is not locked, rotate it clockwise until it does lock, thereby winding the camera.



Photo: Bang Peng / Hasselblad Masters

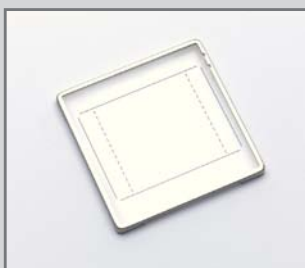

Front protective cover

1

Always fit the front protective cover when no lens is attached to protect the mirror and interior.

Attach the cover as you would a lens, see below. To remove, turn the cover (bayonet fitting) in the direction of the arrow and lift it out.

Rear cover MultiControl

2

Always fit the rear cover MultiControl when no back is attached to protect the auxiliary shutter. Attach the cover as you would a back, see below.

To remove, depress the top part, tilt the cover backwards, and lift it off. See later sections on the other uses of the Rear cover MultiControl.

Opening the focusing hood

3

Lift the lid by firmly gripping the tab on its rear edge, and swinging it up to a vertical position. The hood unfolds automatically and locks in the open position.

Built-in magnifier

4

The magnifier flips up into the viewing position when the oval button inside the lid is moved to the right, as in the illustration. To fold the magnifier down simply press it back down towards the lid until it locks into place. It can easily be exchanged to suit individual eyesight (see "Changing the magnifier").

Focusing screen and viewfinder image

The 503CW/503CWD is fitted with an Acute-Matte D focusing screen for unrivalled brightness and sharpness. The markings on the screen indicate the format of the sensor in the case of the 503CWD for correct composition with digital capture. The screen can easily be exchanged for others specially designed for various applications (see "Changing the focusing screen").

Closing the focusing hood

5

Fold away the magnifier by pressing it back down towards the lid until it locks into place. 'Pinch' in the side plates at the hinge points and then push the lid lightly backwards. The hood then automatically folds back down.

Note

The front protective cover can only be removed when the camera is fully wound.



Winding crank

6, 7

The winding crank can be removed. Push the catch lever downwards while rotating the crank counter-clockwise and pull the crank straight out from the shaft. To attach it, align the small triangular index mark against the red dot on the camera body. Keep the crank pushed against the camera while turning it clockwise until the larger triangular mark is aligned with the red dot where it will click into position.



Accessory rail

8

The camera has an accessory rail on the left hand side for the spirit level and the adjustable flash shoe (for small flash units).



Strap attachment and removal

9, 10, 11

Place the main body of the strap clip over one of the camera's strap lugs. Press the tip of the clip towards the camera while pulling back on the strap so that the clip slides over the lug and locks into position. To remove the strap, lift the clip locking plate high enough to be able pass over the camera lug. Slide the clip in the direction away from the strap until it is free.



503 cw

3

Lenses

The 503CW/503CWD is compatible with lenses that have an integral leaf shutter, namely, all C series lenses. CFi/CFE lenses are the latest developments and are mentioned and illustrated here as the conventional choice. C, CF and CB lenses, although differing in specification and appearance to CFi/CFE lenses, are operated in a very similar manner but please see the relevant instruction manuals for complete details.



Photo: Alexandfelix / Hasselblad Masters

1. Shutter speed ring
2. F-setting button
3. Warning mark
4. Depth-of-field preview knob
5. PC-socket with positive lock
6. Central lens index
7. Focusing distance scale
8. Lens bayonet plate with red index
9. External and internal front bayonets
10. EV index
11. Exposure value (EV) scale
12. Shutter speed/aperture interlock button
13. Shutter speed scale
14. Aperture ring and scale
15. Depth-of-field scale
16. Infrared focusing index
17. Focusing ring



The illustrations show the CFE version of the 2.8/80 mm lens but the layout of the parts is identical on all CFi/CFE lenses.

Shutter speed and aperture

1

The shutter speed selector ring is the ring located closest to the front of the lens. To set the speed, turn the ring until the desired marked shutter speed position aligns with the central lens index. The white scale shows the shutter speeds, and the orange scale the exposure values (EV). The aperture setting ring is the second closest ring to the front of the lens. The aperture value is also set against the central lens index. The diaphragm is automatic and stops down to the preset working aperture at the start of the exposure sequence. Therefore in the illustration, the exposure setting is 1/60 second at f/11.

The orange 'F' setting is used only when the lens is attached to a Hasselblad camera in the 200 or 2000 series with a focal plane shutter. The operation of the diaphragm is not affected. The 'F' setting can only be engaged/disengaged when the orange lever is pressed.

Note

If the F setting is used, exposure errors will occur because the shutter remains open.

Attaching the lens

2, 3

Make sure that both camera and lens are fully wound. Illustration 2 shows the correct relationship between the drive shaft, the lens drive coupling and their indexes. If the lens is not wound, you can insert a small coin or similar in the coupling slot and rotate it clockwise until it locks (about 4/5 of a turn) When you have aligned the red index on the lens with the one on the camera (illus 3), the lens will drop easily into the bayonet fitting. You can then rotate it clockwise until it stops with a faint click as the lens catch locks it in place.



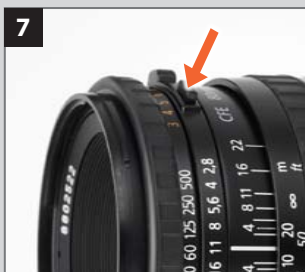

Removing the lens

4

Depress the lens release button and rotate the lens counter-clockwise until it stops and lift it out of the mount.

Exposure

As a general rule for all shutter speed settings except B, you should keep the release button depressed until the lens shutter has opened and closed fully. This is especially important at shutter speeds from 1s to 1/4s, as the auxiliary shutter remains open only when the button is kept depressed (see also 'Warning Mark' below). If you remove the magazine, you can see the auxiliary shutter, consisting of two blinds, covering the rear opening of the camera body. It protects the film from unwanted exposure as the lens' shutter normally is open for focusing.

Warning mark

5

You will find an orangeline on the shutter speed scale above the 1, 1/2, and 1/4s settings. This is to warn you of possible exposure errors as detailed above. The auxiliary shutter will terminate the exposure prematurely if you relax the pressure on the button too soon. Listen to the buzzing sound of the delay escapement in the lens' shutter and maintain the pressure on the release button until the sound stops.

Exposure values

6

The aperture and shutter speed combination set opposite the central lens index determines the exposure. Every combination of shutter speed / aperture has an equivalent exposure value (EV) which you can read and set against the red EV index on the right hand side of the lens.

Interlocked shutter speed /aperture

7

If you want to change the shutter speed or aperture while still keeping the same shutter speed/aperture combination (EV), you can interlock the speed and aperture setting rings by holding down the interlock button which is on the right of the aperture scale. When interlocked, the rings move together, increasing or decreasing the aperture to compensate for a decrease or increase of speed respectively.

Focusing and depth of field

8

The focusing ring is closest to the camera body. It has a knurled rubber grip and engraved distance scales in feet and metres. Focus the lens by rotating the focusing ring until you obtain a sharp image of the subject in the viewfinder. The distance between the subject and the film plane is read off the focusing ring's distance scale opposite the central lens index. Objects closer or further away than the selected distance will be sharp, within certain limits. The limits of this field of sharp focus-depth of field-vary with the aperture. The depth of field available at any given aperture can be read off the depth of field scale on both sides of the central index. As an example, the illustration indicates how to read the depth of field scale at an aperture of f/11. The depth of field will in this case range from ca 6 metres to infinity.

Note

You can only remove a lens when the camera is fully wound and not in the pre-released mode (see "Pre-release and cable release).

Note

For exposure times longer than 1/8 sec when shooting digitally, connect the **Flash sync input cable** (supplied) between the **PC-socket** (flash/strobe sync contact) on the lens and the **Flash sync IN terminal** on the CFV. This eliminates any conflict between the shutter setting and the CFV 'time-out' setting.

Note

See section 'Film Magazines' for information about using infrared film.

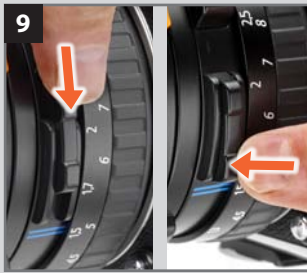

Depth of field preview

9

Depth-of-field can be visually checked on the focusing screen. The diaphragm can be stopped down to the preset aperture from its normally wide open position simply by pushing the depth-of-field preview lever downwards until it locks. To reopen the diaphragm, depress the lower part of the lever.

Pre-release and cable release

10

Considerable efforts have been made to reduce camera vibrations caused by moving parts in the exposure sequence. However, if you wish to avoid these vibrations completely, you can pre-release the mechanism by pushing the pre-release button upwards. This causes the following sequence:

1. *The mirror folds up*
2. *The shutter closes and remains closed*
3. *The diaphragm closes to its preset aperture*
4. *The auxiliary shutter opens*

When you subsequently press the release button, only the shutter then operates at the preset speed. As shown in the illustration, you can also attach a cable release to further reduce vibrations.

Flash/strobe synchronization

11

The C series lenses have built-in leaf shutters with speeds from 1s to 1/500s and B. Flash synchronization occurs at full shutter opening via the PC flash/strobe terminal. Suitable electronic flash/strobe units can be used at all shutter speeds from 1s to 1/500s as well as B. Please see under 'Flash' the sections on the use of a Hasselblad Flash adapter SCA 390.

503 cw

4

Viewfinder System

The 503CW/503CWD is supplied with a light, compact and foldable viewfinder, providing a through-the-lens laterally reversed image. It is easily interchangeable with alternative viewfinders including the prism finders, which produce a laterally corrected image. Please see 'Accessories' for further details about prism finders.



Photo: Lyle Owerko / Hasselblad Masters

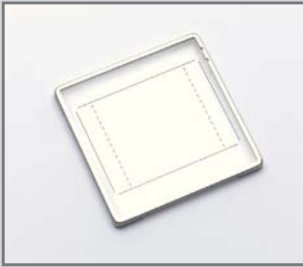

Sensor format markings on the "36x49" screen.

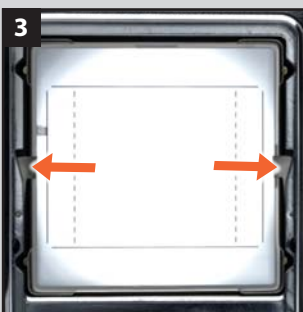

The focusing hood on the standard viewfinder has a built-in 4.5x magnifier for accurate focusing and this can easily be changed to suit individual eyesight. The 503CW is equipped with an Acute-Matte D focusing screen which produces an exceptionally bright and sharp image. The markings indicate the format of the sensor for correct composition with digital capture. The Hasselblad system offers a range of alternative screens for various specific applications, each item easily and quickly interchangeable without the need for special tools or facilities.

Changing the focusing hood or viewfinder

1

To remove the focusing hood so as to attach any other viewfinder in the present Hasselblad system (please note the PM90 is compatible with film magazines only due to its shape), proceed as follows:

1. Detach the digital back.
2. Fold down the focusing hood to protect it from damage and remove it by sliding it to the rear in its guide slots.
3. Slide the replacement viewfinder into the slots and push it forward until it stops.

When fully inserted the viewfinder is retained in position by a spring-loaded catch until you have reattached the magazine.

Changing the magnifier

2

Mounted lenses with dioptré correction from +3 to -4 are available, and are easily interchanged as follows:

1. Remove the focusing hood from the camera and open it by lifting the lid.
2. Release the magnifier by pushing the catch to the right.
3. Push the magnifier halfway back down to its folded position.
4. Grip the lower edge of the magnifier plate (through the underside of the hood), and pull firmly.
5. Keep the plate holder halfway down and insert the replacement lens plate with the printed side up. Fold the hood down and replace on the camera.

Changing the focusing screen

3, 4

1. Detach the magazine and viewfinder.
2. Push the two screen clips to the side into their recesses (fig 3).
3. Place your hand over the screen, and invert the camera. The screen will now drop into your hand (fig 4).
4. Insert the replacement screen, ensuring that the smooth flat side is uppermost and the sharp-edged corners down. Ensure that all four corners of the screen are positively seated on their supports.

You need not return the screen latches. This is done automatically when the viewfinder is replaced.

Should the screen refuse to drop out by itself, ensure that the camera is fully wound, remove the lens and check that the mirror is in the down position. Put a finger through the lens mount and push gently on the screen from underneath, preferably with a soft cloth between the screen and the finger.

Note

Do not immerse the screen in water, or use any kind of cleaning fluid.

Note

Do not use hot air to dry the screen if it becomes damp.

503 CW

5

Film Magazines

A number of different film magazines were produced over the years to accommodate various film types and formats. The film magazine described here is the most recent and common version.



Photo: Claudio Napolitan / Hasselblad Masters

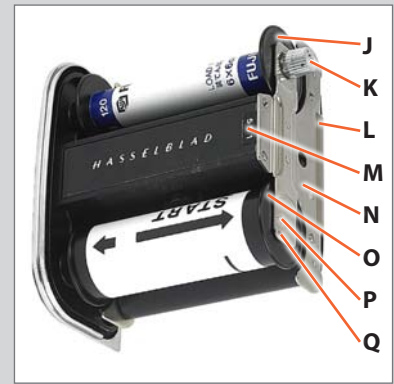
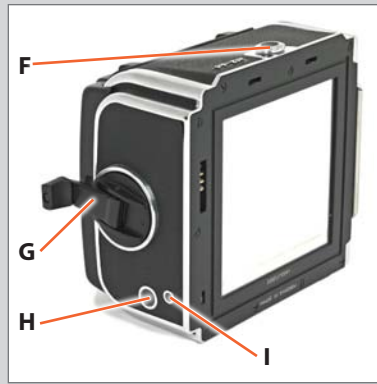
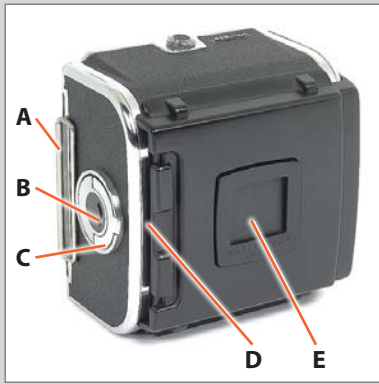

'A12' film magazines accept all 120 size films and produce a 6 x 6cm image. They are easy to use and can be pre-loaded for rapid workflow. They provide the opportunity to vary the type of film used and can be quickly and easily switched mid-film without losing any frames.

There are a number of reasons why using film might either be preferable or even necessary for digital photographers too. For example you might want the specific results you know that a certain film emulsion can produce or you might want to use very long exposure times, etc.

A magazine also functions as an emergency battery-free back up to a digital back. Also, remember that a 6 x 6 cm film magazine use will also allow you to exploit the full focal length of your lenses.

Operation of the magazines is not difficult but pay particular attention to the section on loading. Go through the procedure one step at a time and practice a little until you feel confident. Note especially which way round the spool of film is placed and the positioning of the backing paper under the clamp bar.

The film is automatically advanced frame-by-frame in the magazine by the camera winding mechanism and consequently only when attached to the camera body. Therefore when separated, the magazine and camera body could become unmatched. This can be determined by checking the magazine status indicator or by the winding crank status.



Parts & components

- | | |
|------------------------------|---|
| A. Magazine slide | J. Film take-up spool |
| B. Magazine status indicator | K. Grooved take-up knob |
| C. Film holder key | L. Film clamp |
| D. Magazine slide holder | M. Film holder number |
| E. Film tab holder | N. Spool clamp bar |
| F. Lock button | O. Film supply spool |
| G. Film winder crank | P. Film load index |
| H. Frame counter | Q. Film load index for Ilford black & white film only |
| I. Film advance indicator | |

Attaching the magazine

1, 2, 3

Ensure that the magazine slide is fully inserted with the hinge towards the front of the camera (fig 1) and that the magazine status indicator is white (fig 2). If the indicator is red then see "Magazine status indicator" below. It is also advisable to have the camera fully wound.

Rest the magazine on the magazine supports making sure that the lugs (A) are properly engaged in the recesses (B) (fig 3). Carefully swing the magazine towards the camera body and check that the camera's upper support hooks (C) fit into the slots (D) in the magazine. Push the magazine gently but firmly against the hooks (fig 3) while sliding the lock button

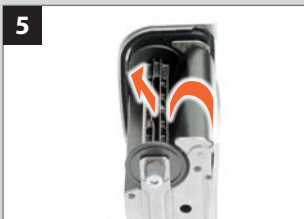

(A) to the right. Release the button when the magazine has made contact with the camera body, and then push the button to the left to ensure that it has reached the locked position. Remove the slide to positively lock the magazine to the camera body.

Removing the magazine

Removing the magazine is simply the reverse of the attaching procedure. It is advisable to have the camera fully wound and the magazine indicator displaying white (see below).

Insert the magazine slide fully with the hinge towards the front of the camera. Slide the magazine catch to the right, swing the magazine back and lift it off the lower supports.

Magazine status indicator

5

The status indicator on the right hand side of the magazine shows white when the magazine is ready to operate and red when the film has not been advanced after an exposure.

If the status indicator shows red, release the camera first before attaching the magazine. Then, winding the camera again will automatically advance the film by one frame.

Loading the magazine

The magazine can be loaded on, or off the camera. If it is to be loaded off the camera, then the magazine slide must be inserted first.

In either case, when inserting the slide ensure that its flat side is towards the rear (see detail in illustration 4) as this facilitates the removal of the film holder.

Step-by-step film loading

1-8

Follow the procedure below in the correct order.

1. Fold out the film holder key.
2. Turn the key counter-clockwise and withdraw the film holder (magazine insert).
3. Place an empty take-up spool under the grooved knob of the spool clamp bar. Insert a roll of film under the other end of the bar, turned the same way as in the illustration. Be sure to remove all of the paper band surrounding a new roll of film.
4. Turn the film holder key clockwise to open the film clamp. Pull 8-10 cm (3-4 in.) of paper backing off the film roll and slide the edge under the clamp.
5. Insert the tongue of the backing paper into the slot in the take-up spool.
6. Turn the grooved knob clockwise until the arrow on the paper backing is aligned opposite the triangular index (or oblong index with Ilford black & white film) on the spool clamp bar, but no further.
7. Turn the film holder key counter-clockwise and insert the film holder into the magazine. Ensure that it is correctly positioned. Turn the film holder key clockwise to lock the film holder in the magazine and then fold the key back into place.
8. Fold out the film crank and rotate it clockwise about ten turns until it stops. Then turn it counter-clockwise and fold it in. The figure (1) will now be displayed in the automatic frame-counter window indicating that the magazine is loaded and ready for use.



Removing film from the magazine

9

When the last frame has been exposed and wound on, the magazine blocks the camera for further release.

Wind off the film by folding out the film winding crank, and rotate it clockwise until you can feel the film leaving the supply spool.

You can now withdraw the film holder from the magazine and remove the exposed film. The frame counter is automatically reset when the film holder is withdrawn from the magazine.

Film tab holder

11

The end tab of the film pack can be inserted in the holder on the back of the magazine as a reminder of the kind of film that has been loaded into the magazine.

Film plane position

12

In close-up photography the film-to-subject distance can be an important factor when determining an accurate focus setting. The red line in the illustration marks the location on the film magazines that coincides with the film plane position.

Double exposure with film

Double (or multiple) exposure is possible with a film magazine. However, as the camera has been designed to prevent accidental double exposure you will have to carry out the following procedure in order to make multiple exposures on the same frame:

1. *Make the initial exposure.*
2. *Insert the magazine slide and remove the magazine.*
3. *Wind the camera with one full revolution of the winding crank.*
4. *Replace the magazine and remove the slide.*
5. *Make the next exposure.*
6. *Repeat the procedure for further exposures on the same frame.*

Note

Do not attach a magazine showing white to a camera that is not rewound! Wind the camera first or you will lose a frame.

Note

The shutter cannot be operated when a magazine, with slide inserted, is attached to the camera.

Note

The magazine cannot be removed without first inserting the magazine slide.

14

Any flash/strobe unit can be connected to the 503 CW / 503 CWD via the PC flash/strobe terminal on the lens for manually controlled flash exposure with flash sync speeds are up to 1/500s.

Automatic flash control, or dedicated flash, is provided by the camera's built-in flash sensor and electronics (TTL/OTF) that measure the light reflected from the central portion of the film; a circle with a diameter of 40 mm.

The metering system is connected to a selector for setting film speed. When an SCA 300 compatible flash/strobe unit is connected through an SCA390 flash/strobe adaptor, the system controls the flash/strobe unit and cuts off the flash when the exposure is correct. Under the left hand edge of the focusing screen an indicator light shows when the flash is ready to be operated and also confirms if the flash output was sufficient to give a correct exposure. The flash/strobe unit powers the camera's electronics and also the flash/strobe adaptor, when that is used.

15

Setting the film speed for TTL/OTF flash

The film speed is set via the ISO selector. This is marked in ISO/ASA settings from 64 – 4000. Note that certain films require compensation due to differences in reflective properties of various emulsions. In these instances, the compensation can be made by changing the film speed selector setting. The amount of compensation has to be determined by experiment. Alternatively you can replace the magazine with the Rear cover MultiControl for a few test exposures. The grey surface acts as an 18% grey card to provide a well-balanced starting point for exposures.

Please refer to your flash/strobe unit's operating instructions for more information about other functions when using an automatic flash light-metering that conforms to System SCA flash/strobe photography with flash sensors, or with non-automatic flash/strobe units.

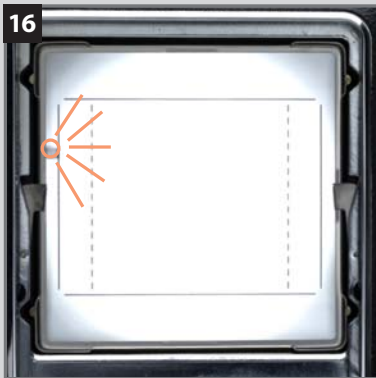
16

Viewfinder indicator

16

Flash/strobe operation and flash battery-check are indicated by a red light, located under the left edge of the focusing screen. It is operative only when a dedicated flash/strobe is connected to the TTL socket. It indicates three separate states as described below.

Ready signal

A steady red light indicates that the flash/strobe unit is charged and ready to be fired. Absence of any signal indicates the need for fresh batteries.

Confirmation signal

A flashing red light occurring for just over a second immediately after exposure confirms that the light output was sufficient for a proper exposure. It then remains dark until the flash/strobe unit has recharged. The steady red light will then reappear indicating operative status again. The time of reappearance however may vary according to the condition of the batteries.

No result signal

Absence of the flashing confirmation signal after exposure indicates that the flash emitted was not sufficient for correct exposure. The aperture must then be opened more or the flash distance to the subject reduced. Changing to a faster ISO setting on the CFV is also a possibility.

See appropriate manuals for connection details regarding the various units and adaptors.

Attaching a Hasselblad flash adaptor SCA 390

For use with hand-held flash/strobe units.

- The 6-pole contact from the spiral cord is connected to the camera's dedicated flash connector.
- The sync cord is connected from the adaptor to the PC flash terminal of the lens.
- The flash/strobe unit connecting cord is attached to the flash/strobe unit.



Note

Please observe the special information that came with your IR film about restrictions concerning magazine loading, film development, etc.

Using infrared film

Infrared (IR) rays (wavelengths longer than 800 nm) form an image on a plane further away from the lens than the image plane for visible light. To compensate for this difference you have to align the chosen distance against the red IR index and not the normal central index. Proceed as follows:

1. Focus as usual on the focusing screen.
2. Note the distance on the focusing scale that is opposite the central index line.
3. Now rotate the focusing ring to set this distance opposite the dashed IR index line instead of the central index line.

General points and tips

- Before you can make an exposure, you must remove the magazine slide. The magazine will then be locked on the camera body, and the camera release button will be unblocked.
- Film is automatically advanced in the magazine after a full turn of the crank.
- You cannot remove a film magazine without re-inserting the magazine slide first.
- Do not attach a magazine showing red to a fully wound camera! This could result in a double exposure.
- The magazine's film winding crank is only blocked at frame 1. A partially exposed film may be wound off at any frame afterwards.
- On the rear of the magazine is a slide pocket where the magazine dark slide can be kept when not in use. Turn the slide with the hinge towards the rear to fold the bow fully into the slide pocket recesses.
- Do not put the film holder down on an unclean surface or where it can attract dust.
- Clean out the magazine housing regularly removing not only dust and particles but also any scraps of paper from previous rolls that may have remained inside.
- Each magazine housing and film holder form a carefully matched pair. Be careful, therefore, when loading more than one magazine at a time not to switch housings and holders. The last three figures of the housing serial number should correspond with the serial number on the film holder.
- Load and unload the magazine away from direct light sources.
- If you keep the slide inserted in an attached magazine, it will act as an exposure lock to prevent inadvertent exposures when the camera and shutter have been wound on.
- Align the arrow on the paper backing of all Ilford black & white films against the oblong index (and no further) on the spool clamp bar and not the triangular index as normal.

503 CW

6

Accessories

Some accessories are still currently available for the 503CW to expand your system and tailor it to suit your needs.

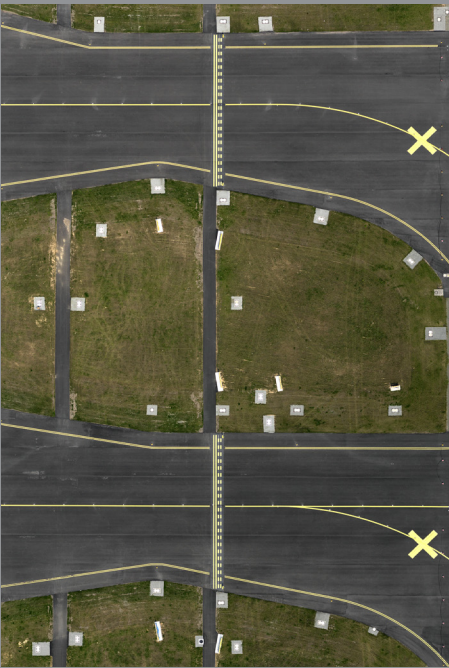

Photo: Stephan Zirwes / Hasselblad Masters



In the diagrams, all exit pupils are viewed from the image corners.

Diagram A

Exit pupil for a wide-open lens



Diagram B

Exit pupil for a vignette-free stopped down lens



Diagram C

Exit pupil for a slightly vignetted lens (no visible effect on the image)



Diagram D

Exit pupil for a vignetted lens (clearly visible effect on the image)



Rear cover MultiControl (supplied)

The Rear Cover MultiControl (3051070) not only provides protection for the camera body when a CFV or film magazine is not attached but also provides flash check facility for cameras featuring TTL/OTF (described separately) as well as a vignetting check facility.

Checking for possible vignetting is useful when filter combinations, attachments or lens shades are used, to ensure the optimum from the accessories without the risk of inadvertent vignetting.

With the cover in position you can see the so-called 'exit pupil' of the lens through the small holes in the cover. A vignetting free lens has an exit pupil the exact shape of the lens aperture. At maximum aperture there is slight vignetting with all lenses but at f/11 to f/16 the majority of lenses are free of vignetting.

Corner illumination is dependent on the size of the exit pupil. If the filter or lens shade extends too far, the area of the exit pupil diminishes. The shading effect of a professional lens shade, for example, is optimal when it has been extended as far as possible without causing any visible corner vignetting. The amount of this extension is dependent on both the working aperture and the focusing distance for the lens used.

Use the following method when any kind of lens accessory is in place and you want to ensure a result free from vignetting:

1. Fit the accessory. Remove the film magazine but do not attach a Rear Cover MultiControl just yet.
2. Set the shutter on a CF/CFi/CFE lens at the 'F' position and pre-release the camera to open both the lens shutter and the auxiliary shutter. C/CB lens shutters should be set at 'B' and a B exposure made. Use a cable release to lock the released position.
3. Look at the lens exit pupil. Use the stop-down button and change the aperture noticing as you do so the changes in the size of the exit pupil.
4. Look now at an angle roughly in a line from the exit pupil to one corner of the camera back opening. This helps in finding the exit pupil again when the RCMC is attached, which can be troublesome with wide-angle lenses in particular.
5. Attach the RCMC and observe the exit pupil again.
6. Select the working aperture and stop down manually.
7. Set the approximate focusing distance.
8. See the diagrams for a fuller explanation of what you can now see through one of the holes, and act accordingly.

Optional accessories

As the 503CW / 503CWD models are further developments of previous models, they feature improvements and some differences in design. This means that certain older and now discontinued accessories cannot be used and any forced attempt at mounting them may damage your equipment, so please check carefully before trying. For example, the PM/PME 90 viewfinders and the ArcBody are not compatible with the CFV-39 or CFV-50 for different reasons but are both compatible with film magazine use. For complete and up to date information please visit our website - www.hasselblad.com. The following list is just a selection (some are discontinued but may still be available).

Viewfinders

A prism viewfinder with a 45° viewing angle that provides an un-reversed 2.5X magnified focusing screen image. The large eyepiece, especially suitable for users with eyeglasses, has a diopter adjustment range of - 2 to + 1 diopters.



Winder CW

The Winder CW is a compact, economically designed unit providing not only a motor drive facility but also a comfortable and robust grip.

It features single exposure, continuous exposure as well as multi-exposure modes. Remote control is achieved by a simple release cord or by the unique infrared transmitter – the Hasselblad IR Remote control. Both provide considerable freedom, with the IR Remote control offering an extra remote mode choice facility. Each winder is governed by a unique code from the IR Remote control so there is no risk of controlling other cameras unintentionally. However, one IR Remote control can control several cameras at the same time if desired. As the winder is set close to the camera body, it produces stability and balance for optimum hand held efficiency.

Requires an 'Exposure Cable 503' when used with a CFV. See **MENU > SETTINGS > Camera** for use.

Tripod quick-coupling

The coupling plate on the bottom of the camera body has both a 1/4 in. and a 3/8 in. tripod thread. It also fits the useful and reliable Hasselblad Tripod Quick-Coupling (3043326). This facilitates rapid and repeatedly accurate attachment and removal of the camera from a tripod or support.

Professional lens shade

The Proshade 6093T (3040739) provides the ultimate in flare and stray light reduction. It is particularly useful if you have a number of lenses as it fits virtually all lenses in the range. It is supplied with a Proshade mask 6093/250 (3040312) which provides further control for longer lenses when the Proshade is fully extended. The Proshade also functions as a gelatine filter holder.

Close-up accessories

Four fully automatic extension tubes are available for close-up work. With the exception of Extension tube 8, which cannot be connected directly to the 200-series cameras, they also feature a data bus coupling to transfer data from the lens to the exposure metering system of the camera.

Film magazine

The Magazine A12 produces 12 frames with 120 film (6x6 cm) and is available in chrome.

Please visit the Hasselblad website – www.hasselblad.com – for details of the complete range of accessories and lenses.

There are a number of discontinued accessories for the V-system on the used market but please check for compatibility.

Technical specifications — 503CW camera body

Camera type:	Single lens reflex camera with 6 x 6 cm (2 ¼ x 2 ¼ in) max. film size. Interchangeable lenses, film magazines, viewfinders, and focusing screens.
Design:	Mechanical, with an aluminum alloy camera body shell cast in one piece.
Viewfinder:	Folding focusing hood interchangeable with reflex viewfinder, prism viewfinders with or without built-in light meter, or magnifying hood.
Film advance:	Manual advance or motor driven with Winder CW. Simultaneous shutter winding. Winder CW winding time: 1.05 s, approx. 0.8 frames/sec in continuous mode.
Flash control:	TTL/OTF-metering. ISO 64–4000 with flash/strobe adaptors SCA390 for connection with flash/strobe units from the SCA 300 systems. Metering area within 40 mm diameter in the centre of the image area.
Tripod coupling:	¼ in. and ⅜ in. socket threads and base plate for quick coupling attachment.
External dimensions:	Complete camera with Planar CFE 2.8/80 mm lens: 193mm L x113mm W x110mm H
Weight:	1620 g (Excluding battery and CF card).
Focusing screen	Hasselblad Acute-Matte D focusing screen with sensor format markings.

Troubleshooting — 503CW

Hasselblad equipment is built to give long and trouble-free service, especially when you follow the maintenance and care advice at the end of this manual. If however you encounter any operating difficulties because you are not familiar with the camera system, the following table may help to resolve them. If the problem persists and the camera is still under guarantee, you should contact your Hasselblad dealer. If the guarantee has expired, you should contact a Hasselblad Authorised Service Center for advice.

Problem	Possible cause	Remedy
There is no image on the focusing screen	<ul style="list-style-type: none"> The camera is in the pre-released or released position The lens cap is still in place 	<ul style="list-style-type: none"> Complete the camera release and rewind the camera Remove the lens cap
You cannot remove the front protective cover	<ul style="list-style-type: none"> The camera is in the pre-released or released position 	<ul style="list-style-type: none"> Complete the camera release and rewind the camera
You cannot attach the lens	<ul style="list-style-type: none"> The lens is in the released position The camera body is in the pre-released or released position 	<ul style="list-style-type: none"> Wind the lens Complete the camera release and rewind the camera
You cannot remove the lens	<ul style="list-style-type: none"> The camera body is in the pre-released or released position 	<ul style="list-style-type: none"> Complete the camera release and rewind the camera

CFV

1

Overview



Photo: Claudio Napolitan / Hasselblad Masters

Introduction

The captured image is temporarily stored internally on a CF card or externally, via a FireWire connection onto a computer hard disk. When tethered to a computer you can remotely make captures using Phocus (see the separate Phocus manual for further details).

As the CFV is a purely electronic device, attention to power supply is vital. When working untethered it is therefore important to plan battery loading / battery replacement to ensure continued workflow. Likewise, image storage is limited and appropriate steps should also be taken when planning a shoot.

When attaching and removing the CFV, pay particular attention to the image sensor area. The sensor itself is covered and protected by a glass IR filter but take great care when handling. If you need to clean the filter, see later section for specific details . When storing separated from the camera, always ensure you have replaced the protective cover.

If you scratch or mark the filter in any way, it will show up on every shot. Replacements are expensive so treat the glass surface with at least as much care as you would a lens. The sensor itself is not accessible for any kind of cleaning or maintenance by a user. Do not attempt any such action as you will almost certainly damage it irreparably. As is the case with all electronic devices pay extra care when working in damp environments and avoid damp conditions for storage.

In keeping with Hasselblad's modular design philosophy, the CFV is an independent component. In this way it can be used with view/large format cameras to optimize its use (see later section for details).

With untethered use, the management of captures is handled by the CFV unit. Tasks such as storage and rating are therefore visible on the display. In tethered use, captures are handled and stored by the computer and are visually checked in Phocus. Check the appropriate sections in this user manual and the Phocus user manual for details.

It is advisable to adopt a method that suits you for checking settings before each shoot. It is easy to forget small adjustments you might have made the time before. A checklist would naturally reflect how you normally work but generally, ISO and White Balance would probably be at the top followed by browse and file storage. There are other features such as the visual and audio signals for IAA rating for example, that you might find invaluable and therefore include them as part of your routine settings. All of these issues are covered in the later sections of this manual.





Computer system requirements

Final image-storage and correction requires a certain minimum standard regarding computer capabilities. Large images will require a high-performance computer with plenty of memory, advanced graphics capabilities and a recent operating system. In most cases, you will want your computer to include a FireWire 800/400 connector, which will enable you to load images directly from the camera. To load images stored on the removable compact-flash card, you could instead use a compact-flash card reader, but we still recommend FireWire for maximum flexibility.

If you want to power the 503CWD / CFV from a PC laptop (as opposed to a Macintosh laptop), you must ensure that the FireWire port on the computer is capable of supplying power.

The 503CWD and CFV save images as 3FR files which are Hasselblad raw digital-camera capture standards. From Phocus, you can optimize and then export the files to 3F, DNG, TIFF, PSD, JPEG formats etc. The 503CWD and CFV include the Hasselblad Phocus image-capture and editing application. Native versions of Phocus are provided for both Macintosh and Windows platforms. Please see the Phocus Read Me files for complete system requirements.

Warnings and restrictions

- *Keep the 503CWD or CFV (and all computer equipment) away from moisture wherever possible. If your camera becomes wet, disconnect from power and allow it to dry before attempting to operate again.*
- *Always take great care when you remove the CFV for cleaning—the exposed glass filter that covers the CCD sensor is vulnerable to damage.*
- *Keep all cables connected to or from your camera and computer out of the way where they will not be tripped over.*
- *Never cover the ventilation openings on the 503CWD or CFV when they are running.*

Note

Regarding the FireWire connection:

- *All recent Macintosh computers are compatible, both desktops and laptops.*
- *Most recent desktop PC computers are compatible.*
- *Most laptop PC computers are NOT compatible (but can be modified in many cases).*

Before you start

Leave protective covers on as much as possible and avoid touching glass surfaces and inserting fingers into the camera body etc.

Please see below for items included with delivery. An informational DVD is also included which contains, amongst other things, a copy of Phocus.

If anything is missing or seems faulty in any way then you should contact your Hasselblad dealer immediately.

Please keep purchase details and the warranty in a safe place.



Protective Case



Protection cover CFV



Adapter EL

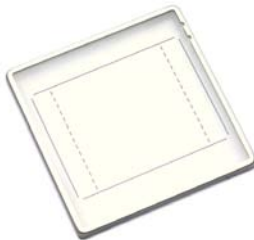

Focusing screen 36x48



CF-Flash card



Grey cards



E-wipes



FireWire cable



Battery Pack F-570 CFV /
Battery Charger 8.4V CFV



Exposure Cable 503



Flash output sync cable



Exposure Cable EL



Flash input sync cable

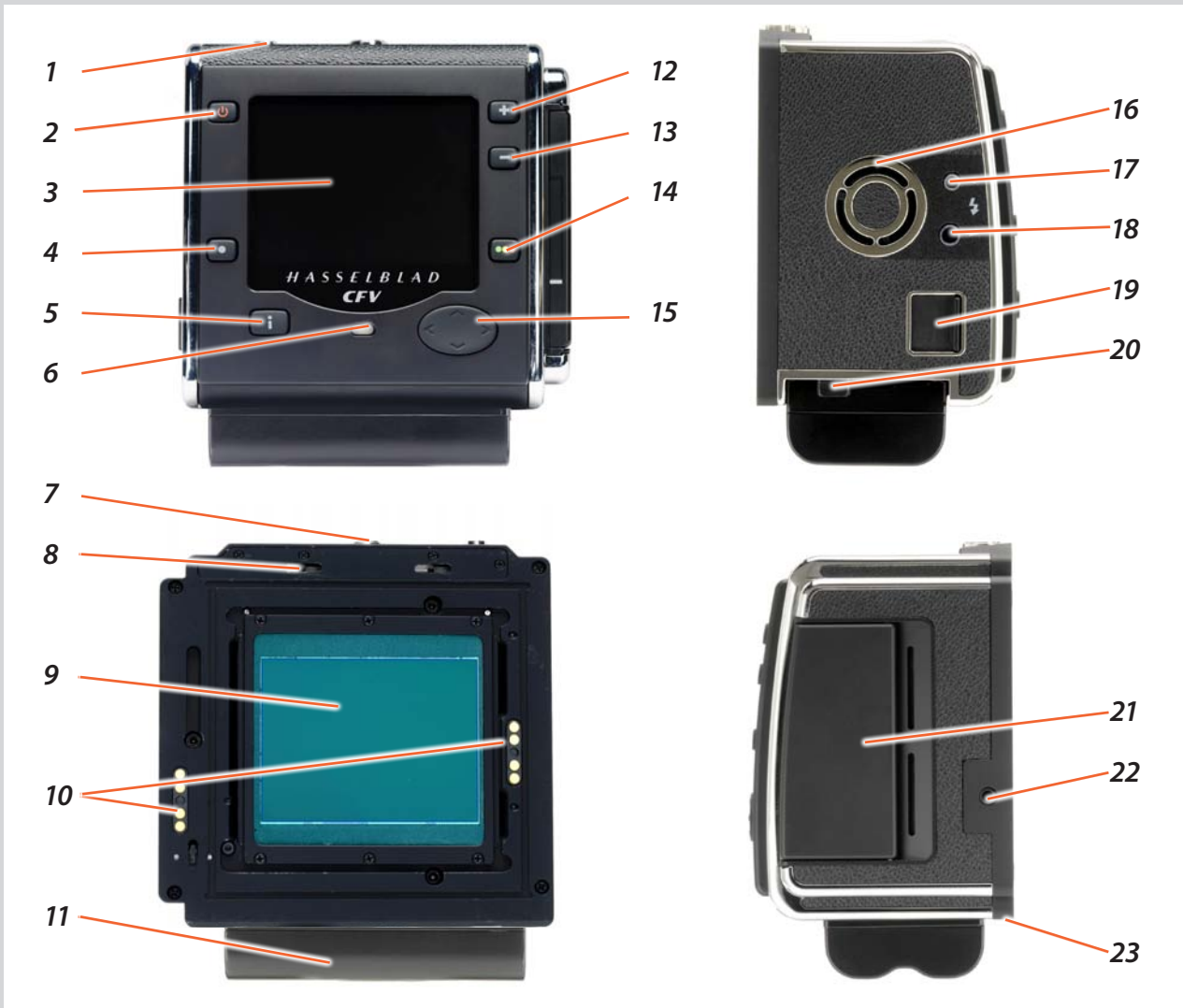

Parts, components & control panel buttons

The interface buttons are used for browsing images and navigating the menu system to make settings. Two of the buttons, located at the bottom-right and -left of the screen, are given an on-screen label that changes according to the current context. For example, the Approval button sets the approval rating when browsing images, but becomes an OK button to confirm settings.

Lock safety button

Prevents unintentional movement of back lock.

ON/OFF button

 Powers the CFV.

Preview screen





Displays preview images and the menu system even in bright light and from acute angles.

1 Menu / (Menu Exit) button 4

 Opens and closes the menu system. Also used for various other tasks (Exit button, for example) as you issue commands within the menu system indicated by a description beside the button on the preview screen.

5 Display mode button

 Steps through the various view modes for the preview image: standard, histogram overlay, image details, screen off and full-screen.

Power indicator	6	Navigation button	15
Glows orange to indicate that the CFV is busy. Glows green when it is ready.			A four-way rocker button enabling you to step through preview images and navigate the menu system. To use it, press the side of the button that corresponds to what you wish to do (e.g., move up, left, right or down).
Lock button	7	Ventilator	16
Locks back into place on camera.		Ensures the processor is kept cool.	
Digital back retaining hook slots	8	Flash sync IN terminal	17
Accepts digital back/magazine retaining hooks on camera body.		Used when working with studio / strobe flash units. Allows connection to the unit via the flash sync protector cable to ensure correct synchronisation as well as providing protection for the CFV.	
CCD and IR filter	9	Flash sync OUT terminal	18
This is the light-sensitive element, which is positioned behind a permanently mounted IR filter. Usually, this assembly will either be inside the camera or protected by the cover. Always be very careful not to touch or scratch the surface of the filter when it is exposed and to replace the protective cover whenever the CFV is not mounted on a camera.		Used when working with studio / strobe flash units. Allows connection to the lens sync contact via the flash sync cable to ensure correct synchronisation.	
Databus connectors	10	FireWire connector	19
For communicating with a Hasselblad ELD model camera body or with a modified Hasselblad 202/203/205 model camera body.		Allows the connection to a computer. The CFV requires an 800 connector whereas the computer can be either an 800 or 400.	
Battery (not supplied)	11	Battery retaining catch	20
7.2V InfoLithium L type (Sony NP-F550 or similar)		Ensures secure mounting of battery.	
Zoom-in button / SELECTION (+ button)	12	CF card slot cover	21
 Zoom-in button (to make the view larger) for the preview image. Also acts as a selection button when viewing available image batches, media and value setting on the menu.		Protects card slot.	
Zoom-out button / SELECTION (- button)	13	Winder / EL terminal	22
 Zoom-out button (to make the view smaller) for the preview image. You can continue to zoom out to view several small images at once and finally to view and select batches and media. Also acts as a selection button for value setting on the menu.		Terminal for connection to a Hasselblad CW winder or Hasselblad EL model camera body. Requires the camera sync cable (supplied).	
Instant Approval / (OK) button	14	Digital back support slots	23
 This button steps through the three approval levels, thereby assigning an approval status to the image currently displayed (or selected) in the preview screen (part of the Instant Approval Architecture system). The color coding is based on the traffic signal convention of green, amber (yellow) and red. Also acts as a confirmation button (OK button) for some types of menu operations, such as deleting images; indicated by a label beside the button on the preview screen.		Accepts digital back/magazine support hooks on camera body.	

Note

When you attach or remove the CFV, be very careful not to touch or scratch the glass IR filter surface.

Always attach the protective cover for transportation or storage.

Note

IMPORTANT

Never attempt to remove the glass IR filter – you will probably ruin the sensor if you do so.

See the 'Cleaning' section for details.

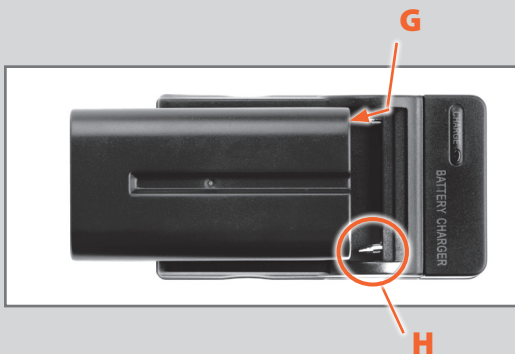
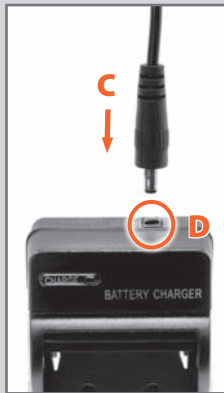
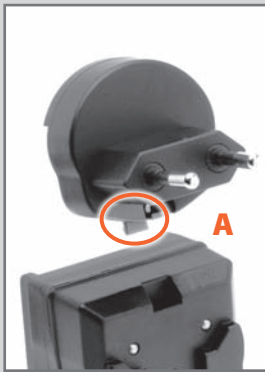

Battery attachment/removal

As with all mobile digital products, it is essential that you maintain a check on battery condition. It is recommended that you have a fully-charged reserve battery with you at all times when not tethered to a computer.

The **Battery Pack F-570 CFV** (3051094) is the recommended power source for the Hasselblad 503CWD and Hasselblad CFV (all models). It is a rechargeable and environmentally approved Li-ion type.

Battery Charger 8.4V CFV

The **Battery Charger 8.4V CFV** (3051092) is designed for use with the **Battery Pack F-570 CFV** only. It is supplied with four plug attachments; three to suit various types of domestic power-sockets available worldwide and one to suit automobile power-sockets. Other types of domestic power sockets will require a domestic socket converter to accept the plug attachments supplied.

The Battery Pack F-570 CFV and the Battery Charger 8.4V CFV may be supplied bundled as (3051096).

Plug attachments

Domestic plugs: Choose a suitable plug attachment to match the power-socket type. Ensuring that the securing catch (A) is correctly oriented as in the illustration, slide the plug attachment into position onto the charger unit. Continue pushing the plug attachment in the same direction until clicks into place. The plug attachment is now automatically secured by the securing catch.

To remove a plug attachment, depress the top (B) of the securing catch to release it while simultaneously sliding the plug attachment in the reverse direction to fitting.

Automobile plug: Insert the DC power plug (C) into the 12-24v input socket (D) on the charger unit.

Battery charging

Domestic plugs: Insert the battery charger into a standard (100–240V~/50–60 Hz) domestic socket.

Automobile plug: Insert the plug unit (E) (suitable for 12v/24v systems only) into a power/cigarette lighter socket in an automobile. Ensure that the indicator lamp (F) is illuminated.

Battery attachment/removal

Firstly, ensure the orientation of the CFV battery 7.2v is correct (with the connectors (G) toward the top of the Battery charger CFV, as in the illustration). Place the battery down onto the charger, leaving a small gap as in the illustration. Slide the battery upwards ensuring that prongs (H) on the charger enter the connectors on the battery. Remove the battery by sliding it back downwards.



Charge indication

When connected to a power socket, the indicator lamp (i) on the charger displays three conditions:

With NO battery attached	GREEN — the charger is functioning correctly.
With a battery attached	RED — the battery is charging. GREEN — the charging process is complete and the battery can be removed.

General

- The battery should be charged for approximately 12 hours before first time use.
- Maximum battery capacity is reached only after the battery has been charged and discharged several times.
- The battery is best charged at an ambient temperature of 10°–45°C (50°– 113°F).
- Avoid frequent full discharges. As the battery is a Li-ion type, it has no 'memory effect' of practical importance and therefore frequent recharges will cause no problems such as loss of capacity or poor performance. It is therefore better practice to recharge the battery at very regular intervals, regardless of use.
- Remove the battery if you intend to store the camera for some while as it will eventually become completely drained, even though the camera/CFV is turned off.
- When removing a battery from the charger and immediately replacing it with another, allow a few seconds to elapse so that the charger can automatically reset for the next charging procedure.
- It is perfectly normal for the battery to become warm when being charged.
- A slight temporary loss of battery performance might be noticed at very high or low temperatures. Take the appropriate measures if this is the case.
- If you do not intend to use the battery for a while, it is best to store it in a cool place (in a domestic refrigerator is ideal).
- The battery should have a usable service life of around 300 recharge/discharge cycles.

Battery Pack F-570 CFV – precautions

- Connect the battery to the CFV correctly.
- Do not use the battery for anything other than Hasselblad CFV digital backs.
- Do not immerse the battery in liquids.
- Do not incinerate the battery. Please recycle or discard in an environmentally approved manner.
- To charge, do not use any other charger than the Battery Charger 8.4V CFV.

Battery Charger 8.4V CFV – precautions

- Read the instructions before using the charger.
- Use indoors only (protect against moisture).
- Do not use the charger for anything other than charging a Hasselblad Battery Pack F-570 CFV.
- Do not alter the charger in any way other than changing the plug attachments.
- Ensure the power socket (domestic/automobile) specifications match the specified requirements of the Battery Charger 8.4V CFV.

Technical specifications — Battery Pack F-570 CFV / Battery Charger 8.4V CFV

<i>Battery:</i>	Li-ion type
<i>AC input voltage:</i>	100–240VAC
<i>DC input voltage (via adapter supplied):</i>	12–24V (Short-circuit protected)
<i>Storage temperature:</i>	-20° C through 45° C
<i>Usage temperature:</i>	0° C through 45° C
<i>Usage humidity:</i>	10% through 95%

Attaching and removing the CFV

1



When both attaching and removing the protective cover as well as attaching and removing the CFV to the camera, hold down the lock safety button **A** while sliding the lock button **B**. Avoid trying to just 'snap' the CFV or protective cover into place without using the buttons.

Powering the CFV

2 – 4

The CFV requires power either from the battery (7.2V Sony InfoLithium L type – NP-F550 for example) or from a computer via a FireWire cable.

To attach a battery:

1. Firstly, ensure the battery is fully charged (see user appropriate manual for battery and charger).
2. Position the battery as in the illustration.
3. Press the battery towards the camera **C**. This automatically depresses the battery retaining catch. Slide the battery into the final position **D** ensuring the contact prongs on the camera are inserted into the battery. The battery retaining catch will now return to the safety position.

To remove a battery:

Depress the battery retaining catch and slide the battery over it. It will then be freely removed.

FireWire connection:

4. Simply connect the FireWire cable between the FireWire port on the CFV and the FireWire port on the computer. You will not need to attach a battery with a FireWire connection.

ON / OFF button



With a fully charged battery fitted, keep the **ON/OFF** button depressed for at least two seconds. (This time delay helps prevent unintentionally turning the CFV on.) A Hasselblad logo splash screen will appear on the display followed by an audible signal. This signifies that the CFV has been activated.

The CFV will enter standby mode after the preset time to save the battery. Keep the **ON/OFF** button depressed again to turn the CFV off. An audible signal will be heard again to confirm this. (If it appears that you have to press the button twice to turn it off it is because the CFV has already entered standby mode.)

However, you will not need to use this button with a FireWire connection as the active mode is instigated automatically. The splash screen appears but no audible signal is heard from the CFV. There may be an audible signal generated by the computer, however. Removing the FireWire connection turns the CFV off immediately, also without an audible signal from the CFV.

Battery warning

5

A warning on the display (fig. 6) appears as a flashing yellow icon in the top right of the screen signifying that the battery should be charged (or changed) as soon as possible. The warning icon will also appear with a FireWire connection and will in addition turn red to signify that the camera battery is completely exhausted.



Tip

Change the **Time Out and Power Down** settings to reduce battery consumption.

Note

Time & Date settings on the CFV (which are included with your capture files and batch labels) are updated automatically through a FireWire/Phocus connection. These settings are retained for about two consecutive weeks by a small rechargeable cell that is automatically recharged by the main battery or FireWire with regular use.

If problems occur, charge the cell by leaving the CFV ON for approximately 12 hours.

Flash / Strobe

Various configurations of cables are needed to match the requirements of various CFV / Hasselblad body combinations. In addition, some modification might be required for certain camera bodies. Neither of these points however are directly related to CFV use but rather to general flash use. See the chart on the following page for details.

CFV and 503CWD or 503CW+CFV combination

A 503CWD or 503CW+CFV combination offers TTL flash control with some slight adjustments. As the reflective characteristics of the digital sensor are different to film surface characteristics (for which the TTL function was originally designed), this function has to be slightly 'tricked' to perform correctly. Proceed as follows:

Move the film speed selector on the camera so that it becomes approximately $1\frac{2}{3}$ f/stop higher than the ISO setting on the CFV. Therefore, for example, when the CFV is set at 50 ISO, the 'film speed setting' on the camera should read 160 ISO, and so on. Testing for the most suitable compensation that suits you is recommended.

See section on 503CW /Viewfinder indicator in this manual for further details.

Studio flash/strobe units when tethered to a desktop computer

If the 503CWD/CFV is tethered to a computer that is connected to a regular electricity supply system as well as a studio flash/strobe unit that is also connected to a regular electricity supply system/generator system, then make the following connections instead. For your own safety and to protect the electronics in the CFV, please ensure you do this correctly.

- a) Connect the **flash input sync cable** from the sync contact (PC connector) on the lens to the **flash sync IN terminal** on the CFV.
- b) Connect the **flash output sync cable** from the **flash sync OUT terminal** on the CFV to a regular flash/strobe sync cable that is connected to the unit.

CFV and Hasselblad 200 series cameras

Connection to 200 series cameras depends on whether they are modified or not (contact your local Hasselblad Service Center about modification). TTL is also possible if the flash/strobe unit allows. See the appropriate camera manual for further details.

Please note the difference below – unmodified cameras can only use C lenses (C/ CF /CFi etc) at the C-mode setting whereas modified cameras can use C and F-type lenses.

Unmodified cameras (with portable flash/strobe units) with C type lenses:

- a) Connect the **flash input sync cable** from the sync contact (PC connector) on the lens to the **flash sync IN terminal** on the CFV.
- b) Connect the **flash output sync cable** from the **flash sync OUT terminal** on the CFV to a regular flash sync cable that is connected to the unit.
- c) Use the C-mode setting.
- d) Shutter speeds faster than 1/90 sec allowed.

Modified cameras (with portable flash/strobe units) with C type lenses:

- a) Connect the **flash input sync cable** from the sync contact (PC connector) on the lens to the **flash sync IN terminal** on the CFV.
- b) Connect the **flash output sync cable** from the **flash sync OUT terminal** on the CFV to a regular flash sync cable that is connected to the unit.
- c) Use the C-mode setting.
- d) Shutter speeds faster than 1/90 sec allowed.

Modified cameras (with portable flash/strobe units) with F and CF type lenses:

- a) Connect the **standard PC /flash / strobe sync cable** from the sync contact (PC connector) on the camera body to the unit.
- b) Use F type or CF type lenses at the F-mode setting.
- c) Use a shutter speed no faster than 1/90 sec.

Note

Pay particular attention when using studio flash/strobe units in conjunction with a desktop computer. Ensure you use the correct configuration to guard against both personal injury and damage to equipment.

Flash / strobe connection for CFV digital backs.

Please note the different ways of connecting the various camera body / CFV / flash / computer combinations.

In particular, notice the importance of the correct connections when using a FireWire link directly to a desktop computer in combination with studio flash/strobe.

The Flash input sync cable, Flash output sync cable and FireWire cable are supplied.

TETHERED / studio / computer

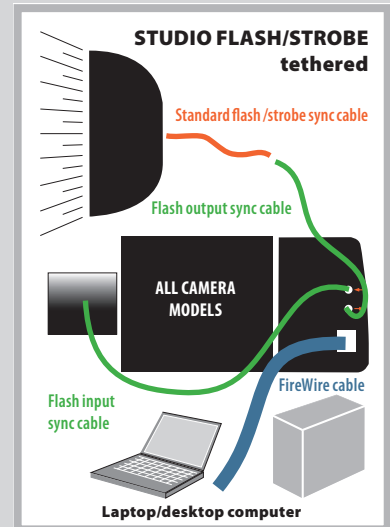

TETHERED / portable / laptop

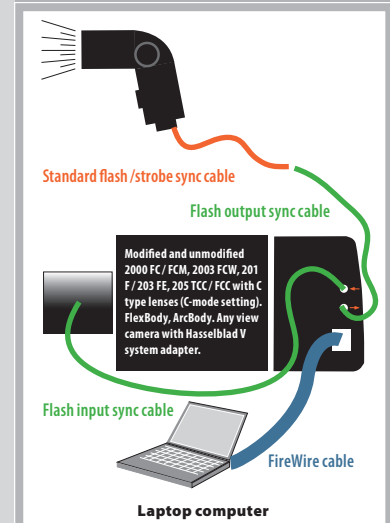
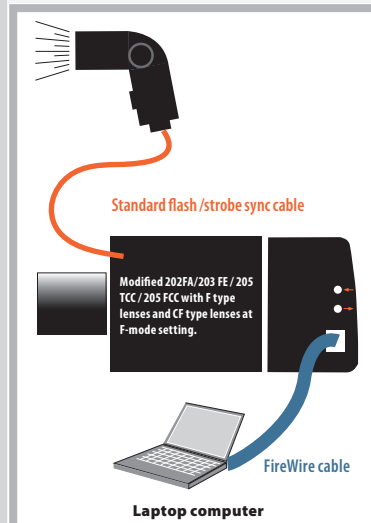
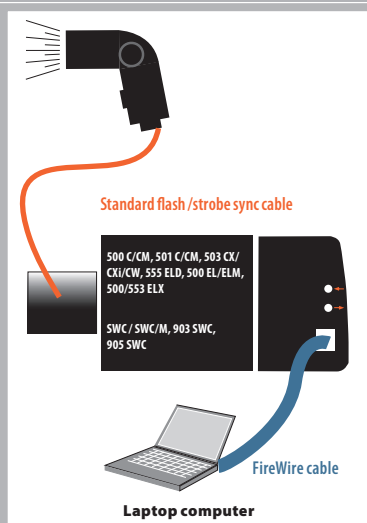

UNTETHERED / portable / CF card

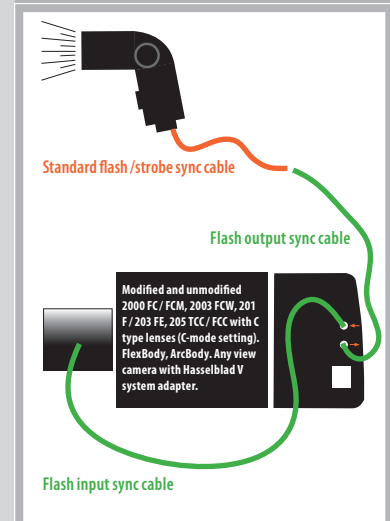
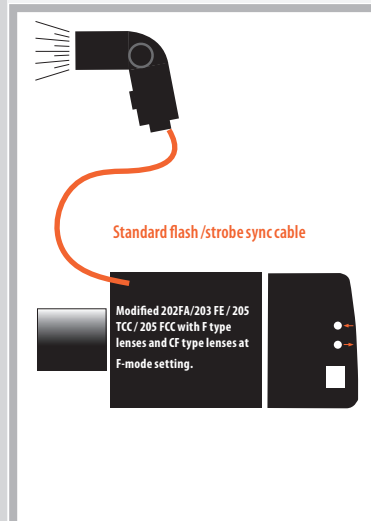
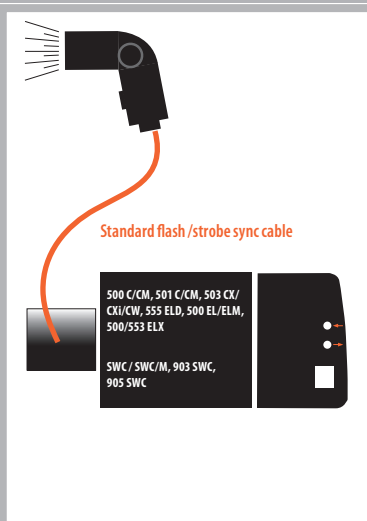

Simple introductory overview of menu access, navigation and settings choice.



The menu is structured in a manner similar to cell phones and similar electronic devices.

Various branches within the tree system are accessed by pressing the navigation button until you reach the point where a choice has to be made.

The OK (Approve) button or SELECTION (Zoom-in/Zoom-out) buttons are then used to confirm choice.

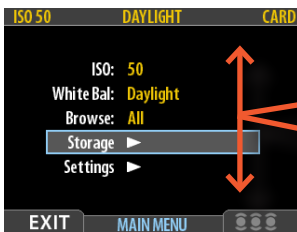

After pressing the MENU button, the main menu list appears. The blue frame highlights where you are on the menu. Press on the 'up' and 'down' symbols on the navigation button to move up and down the list.

You can return to the standard image view by pressing either on the 'left' symbol on the navigation button or on the EXIT/MENU button again.

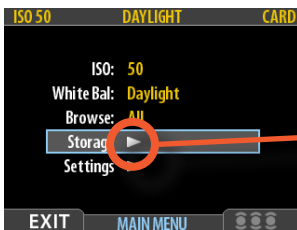

The need to continue further into the menu is indicated by the arrow symbol beside the menu item.

Press the 'right' arrow symbol on the navigation button to access the next part of the menu.

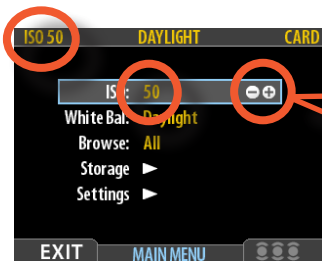

When you reach the final destination of your choice (this might take several moves), PLUS and MINUS symbols appear to the right in the frame round the item.

You then press the Zoom-in /Zoom-out /SELECTION buttons to access a loop list of choices.

In the example on the left, 50 is the ISO value shown. By pressing either button the alternatives appear – 100, 200, 400 and then back to 50 again – both on the list as well as on the upper low to the left (in the case of ISO value).

Pressing the EXIT/MENU button will then confirm the new setting.

In the next example on the left, the name of a new batch is changed by pressing a combination of the Zoom-in /Zoom-out/ SELECTION buttons as well as the navigation button. You can then confirm your choice with the OK (Approve) button or revert to the previous status by pressing the EXIT/MENU button. Note that how for this screen the MENU button is now described as EXIT on the screen, and the Instant Approval button is described as the OK button.

See later sections for more comprehensive information.

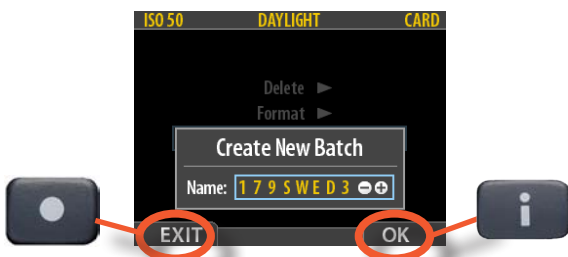

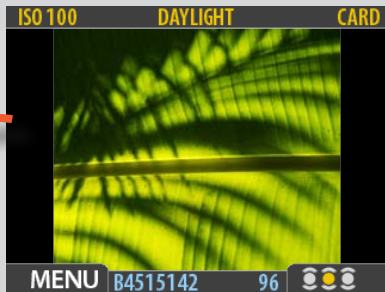

By using the buttons on the control panel you can navigate down through the various levels in the menu. It provides the source of information about image files and also provides a way of making custom settings so the CFV suits your way of working.

Below is a simple overview of what is available and where it is situated on the menu.

Overview of menu structure

MENU



- ISO**
Sets the light sensitivity of the sensor. Equivalent to 'film speed'.
- WHITE BALANCE**
Set to match the color temperature of light used.
- MEDIA**
(16 & 39 Mpix models only)
Determines where files will be stored (CF card or ImageBank-II)
- BROWSE**
Sets the approval status (classification) filter for easier and quicker image browsing.

STORAGE

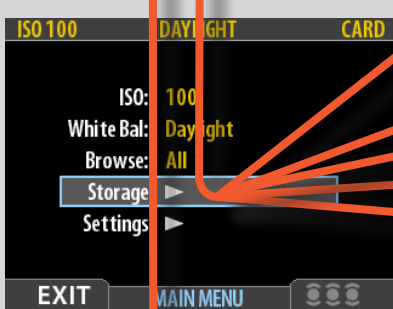

- DELETE**
For single or multiple deletion of images.
- FORMAT**
Used to format CF cards..
- COPY**
(16 & 39 Mpix models only)
Copies files from a CF card to an ImageBank-II.
- BATCH**
Used to create new storage folders (batches) and name them.
- DEFAULT APP LEVEL**
Assigns a default approval status (classification) to all new images.

SETTINGS

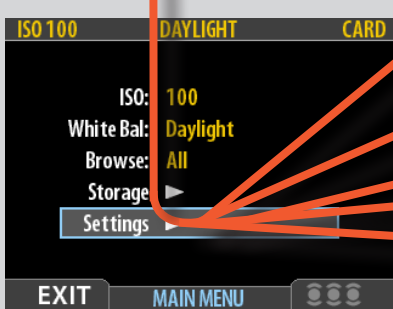

- USER INTERFACE**
Sets menu language, power down, sound, date & time and several other custom settings.
- CAMERA**
Sets which type of camera body to be used with the CFV.
- CUSTOM OPTIONS**
Sets options regarding image format and tilt sensor (CFV-39 and CFV-50 only).
- ABOUT**
Displays serial number and firmware version.
- DEFAULT**
Resets all custom settings back to the original factory settings.

Storage and Settings menu structure overview

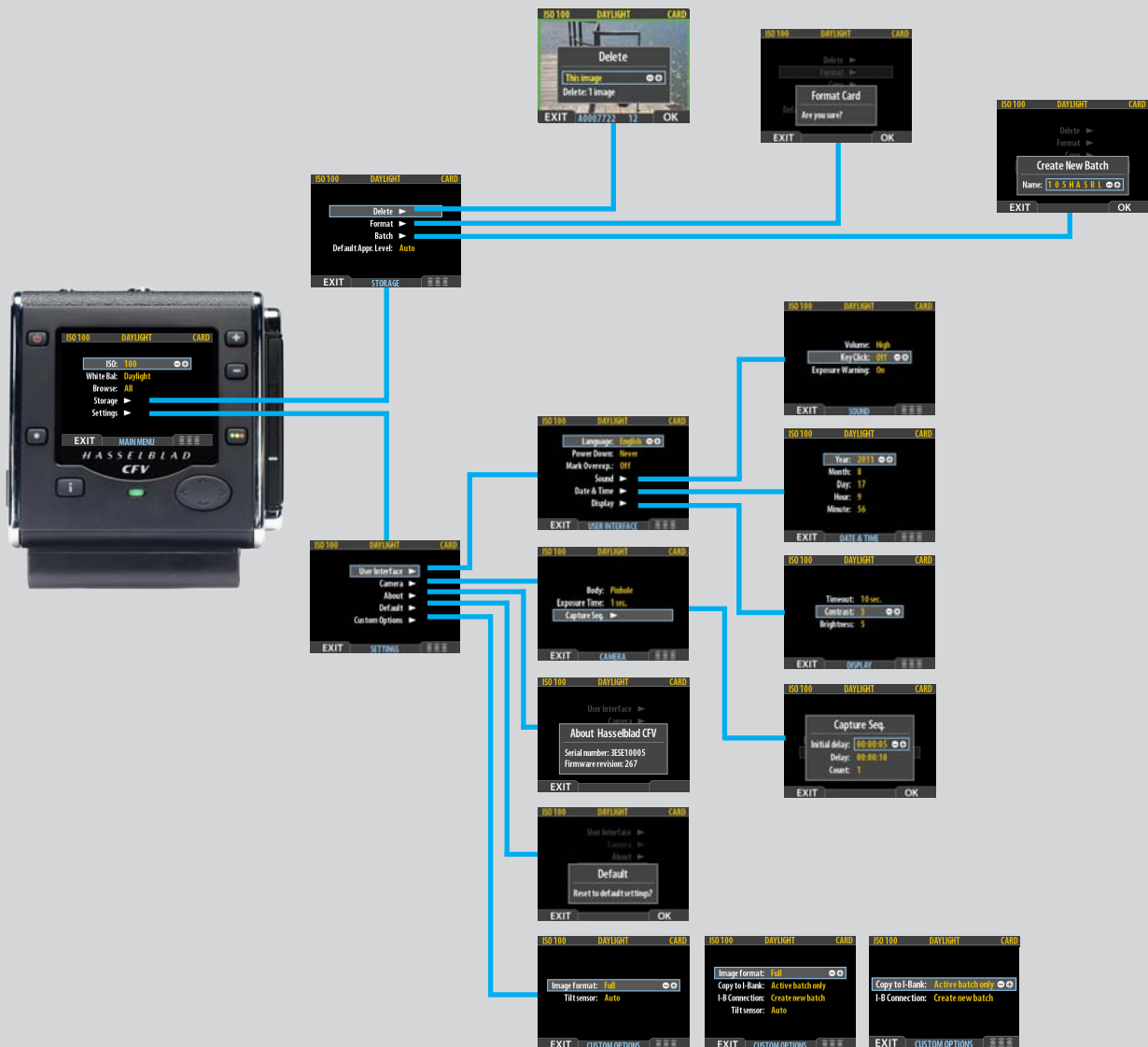

(This screen will vary according to model – see later section for details)

Here you can see where some of the main screens are situated with regard to each other. Accessing them is just a matter of tracing along the paths using the **Navigation** button.

You can revert by either pressing the **Navigation** button in the opposite direction or the **Menu/Exit** button.

CFV

2

Getting Started



Photo: Mark Holthusen / Hasselblad Masters

File storage

The CFV captures images as 3FR files (see below). These can be stored in three ways:



Untethered / Compact flash card mode

In this mode the 503CWD and CFV act independently of other connections. Images are stored on the internal, removable compact-flash card.

- The main advantage with this mode is the freedom of cables and extra equipment.
- The main disadvantages with this mode in the field are the battery power capacity and the size of the card's holding capacity.

Please note that the recommended types of CF cards are Sandisk Extreme-III or Lexar Professional 133x. Other cards will work but offer a reduced capture rate.

Tethered / Studio mode

This mode enables you to connect the 503CWD and CFV directly to a computer and to operate the system using Hasselblad Phocus software and store images on a computer hard-disk.

- The main advantages with this mode are the almost limitless storage capacity and being able to work on the images (with Hasselblad Phocus) on a large screen.
- The main disadvantage with this mode is the lack of mobility to any great extent.

ImageBank-II mode

This mode applies to the use of the now discontinued ImageBank-II portable hard disk. See next page for details.

Capture destination

The capture destination is the location to which new captures are saved and from which you can browse. Choice is normally automatic but a manual selection is also possible in some cases:

- When untethered, a compact-flash card is automatically selected.
- When tethered, captures are automatically saved directly to the computer hard disk. See Phocus user manual about how to select or create a new storage folder.
- When using an ImageBank-II, see next page for storage media selection details.

Hasselblad 3FR /3F files

3FR is a proprietary Hasselblad format for the temporary storage of captures. A 3FR contains the complete digitized raw image exactly as it was captured by the camera. 3FR information requires further computing power (typically by way of Phocus) to obtain complete development. If developed in Phocus, 3FR files become Hasselblad 3F files – denoted by each file now bearing the suffix “.fff”. If developed by other RAW processors, the 3FR files are not converted to 3F but can be exported directly to TIFF, PSD etc according to requirements.

Untethered: When working untethered, CF cards store 3FR information that can be developed to completion using:

- Hasselblad Phocus
- Adobe Camera Raw / Lightroom
- Apple Aperture

Using Phocus is the most comprehensive method. The Phocus and Adobe methods can produce almost identical results (in most cases, but not all) regarding RAW conversion so it is a matter of personal choice regarding which method would suit your preferred ways of working best. Alternatively you can use Apple Aperture though you should take note that the benefits of DAC and HNCS etc, will be lost in this case.

Tethered: When working tethered (which necessitates using Phocus), 3FR files are automatically developed and stored in the background as 3F files on the computer hard disk ready for selective adjustment and export.

In all cases if you keep the original 3FR/3F files, you will also retain the possibility of reprocessing them in the future in the latest version of Phocus, for example.

See the Hasselblad website for in-depth information about which method would suit you best.

ImageBank-II (discontinued product)



The Hasselblad ImageBank-II is a portable 100MB hard disk that provides high-speed image-file storage for use with Hasselblad digital backs. Though discontinued, some units are still currently available (new and used) from various sources.

As the item is no longer produced, there is limited provision for it in the current firmware update for the latest CFV models. This results in variations in use, the main division being between the 16/39 Mpix models and the 50 Mpix models, as they rely on different firmware configurations.

So, more simply put, if you use a 16 or 39 Mpix model, the menu will show more information and allow more possibilities than the 50 Mpix model regarding any eventual ImageBank-II use.

Below is an overview of menu items and possibilities with the two general types of back. See the later sections in this manual for further details regarding file copying etc.

Please note that as the ImageBank-II is a discontinued product, general support is no longer available from Hasselblad.

16 & 39 Mpix models only

Media appears on the menu lists of the 16 and 39 Mpix models. When a CF card is in place and an ImageBank-II is attached, either **Card** or **ImageBank-II** can be selected using the zoom (+ & -) buttons.

Alternatively you can navigate from a browsed image to the media choice screen by using the zoom buttons. You can then select either the CF card or the ImageBank-II.

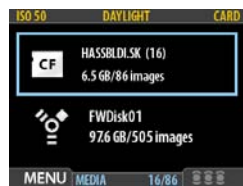

Blue frame indicates which medium is selected.

50 Mpix models only

Media does not appear on the 50 Mpix model menu because media choice is automatic (an inserted CF card will always override a connected ImageBank-II).

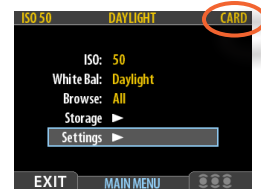

16, 39 & 50 Mpix models

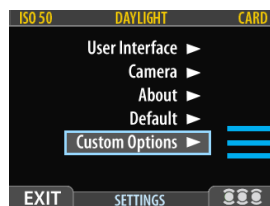

Custom Options selected
(all models)

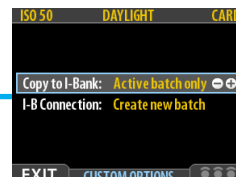

16 Mpix model choices

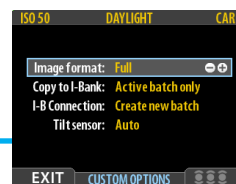

39 Mpix model choices

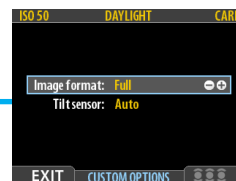

50 Mpix model choices

Using compact flash memory cards

When shooting to a compact-flash card, the CFV is completely self-contained. No additional wires or connectors need to be attached.

Lossless compression is applied to the images, so the actual size of each capture can vary, thereby affecting the total number of shots you can fit on a card. It is good practice to regularly reformat CF cards. This is a quick and easy process with the CFV (see under 'Format').

Inserting a card

1. Open the CF card door to reveal the CF slot.
2. Hold the CF card so that the connector holes face into the slot, with the brand label facing in the same direction as the preview screen. Gently press the card into the slot.

If you encounter resistance, it might be because you are holding the card backwards or upside down.

When the card is completely inserted, swing the door shut again.

Removing a card

1. With the CF card door open, press gently on the card removal button (1a) and then release it. It will now extend out from its original position, as in the illustration (1b).
2. Push firmly on the card removal button (2a) to eject the card for removal (2b).

Formatting CF cards and other media

The CFV is only able to read and write to cards and disks that have been formatted, which is easily achievable with a CFV. Although older cards or cards used for other purposes should be formatted, it is also advisable to format new cards to increase security and file storage capabilities.

To format media:

1. If you have more than one type of medium connected (e.g., a compact-flash card and ImageBank-II), then start by selecting the medium you wish to format using the **Storage** item of the main menu (see also **Selecting the Current Storage Medium**).
2. Select **MENU > STORAGE > Format**. (See also **Navigating the Menu System** for details about how to find this setting.)
3. Press the **▶** to open the **Format Card** dialog.
4. You are now asked to confirm the operation.
 - To confirm, press the **OK** button. This will carry out the format and delete all data on the current medium.
 - To cancel, press the **EXIT**.

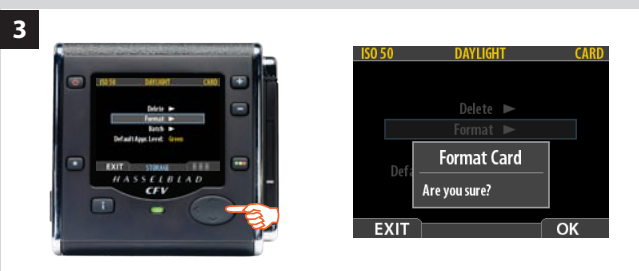
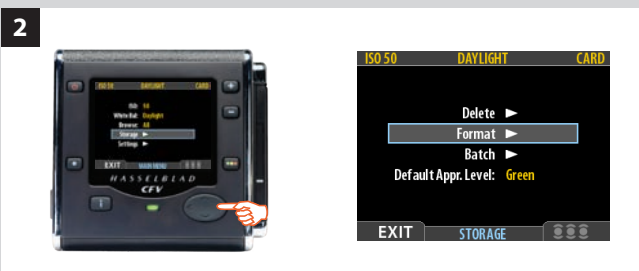
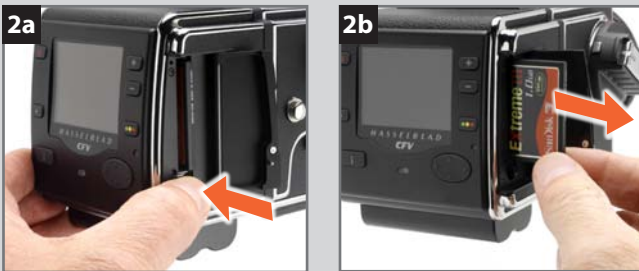
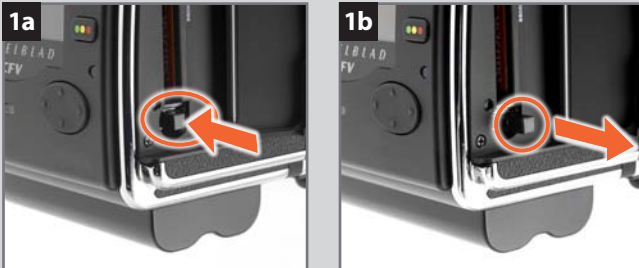
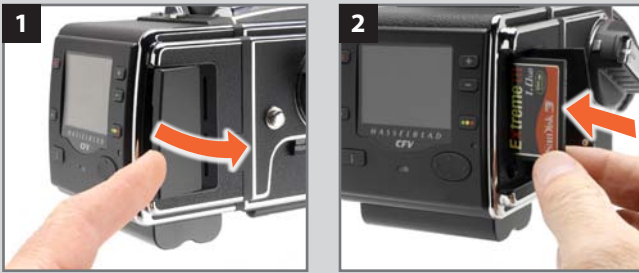

4



5



5. You now return to the **STORAGE** menu. Either move on to another setting by using the navigator button or press the menu (**EXIT**) button to exit the menu system.

Tip

Each time you get a new compact-flash card, it is recommended that you format it using the CFV as described below, even if the CFV is already able to read it. This will enable the CFV to use the card more efficiently.

Tip

You can also use the format command for the purpose of deleting all images on a disk. This is sometimes faster than using the delete function, but it is not as flexible because all data from all batches will always be erased.

Note

The CFV is capable of formatting any type of medium connected to it, including compact flash cards. When you do this, you will erase all data contained on the target medium.



Tethered to a computer

Even if you never shoot while connected, you will probably connect the camera to your computer each time you want to download your images, though you might instead use a compact-flash card reader.

Connecting to a computer

To connect to a computer, simply attach a FireWire cable from the FireWire port on your computer to the port on the side of the CFV. The port is protected behind a sliding cover.

Disconnecting from a computer

To remove the camera from a computer, disconnect the FireWire cable when all image loading activity has finished.

Shooting with Phocus running

When you are connected to a computer and you want to control the camera from Phocus, the following rules apply:

- *A Winder CW and the Exposure Cable 503 (supplied) must be attached.*
- *The destination medium and location are controlled from Phocus.*
- *The screen and menu system on the CFV are disabled.*
- *The CFV will take power via the FireWire cable if it is available (not all computers supply power, notably PC laptops. See under 'General Information' for details).*

When using a 503CWD or 503CW+CFV and initiating a shot from Phocus, the computer sends a signal to the CFV, which triggers the Winder CW which in turn triggers the shutter and flash/strobe lights (if any). The CFV then sends the image back over the FireWire connection to the computer, where it is displayed on the computer screen and saved as a 16-bit-per-color 3FR file in the currently selected folder of the computer hard disk.

INITIAL SETTINGS







The initial general setting is language choice. This choice is retained but can be changed at any time. You can choose between: English, German, French, Italian, Spanish, Japanese and Chinese.

Before each shoot an ISO and a white balance setting should be made (white balance is for your convenience regarding the appearance of the image on the display though; it will not affect the raw file. See next chapter for details).

Although the description below illustrates how the language choice is set, it is also a general introductory illustration of how settings are changed.

Setting the menu language

Proceed as follows:

1. Press the **MENU/EXIT** () button to open the menu.
2. Press the **NAVIGATOR** button () to select the **SETTINGS** sub-menu.
3. Press the **NAVIGATOR** button () to open the **SETTINGS** menu.
4. Press the **NAVIGATOR** button () to select the **USER INTERFACE** sub-menu.
5. Press either **ZOOM** button ( or ) to choose a new language (in this case, Spanish).
6. Press the **MENU/EXIT** () button again to close the menu.

Camera settings



A CFV can be used together with a number of different camera models and requires different camera compatibility settings accordingly. Settings apply not only to specific models but to exposure times too, so you should include this setting when making pre-session checks as well as keeping it in mind when changing shutter speed. See later section **Settings** for full details.



Tip

If you find the CFV has been set to a language you don't understand (a rented camera, for example), you can use the procedure above to get back to your preferred language just by following the actions and appearance in the illustrations here.

Note

Note that the **Menu** () and **Approval** () buttons change name on the screen according to function.

As you work through the various menu items, the screen shows a label for each of these buttons. So, for example, the **Approval** button will be labelled and function as function as the **OK** button when that particular action demands it.

1



2



3



Tip

The default sensitivity of the CCD sensor is ISO 50. Higher ISO settings result in progressively noisier images (just as higher ISO film becomes grainier). It is recommended that you use the lowest ISO setting the lighting situation allows.

1



2



3



4



Regular menu checks

ISO, White Balance, Media and Browse settings should be checked before each session. They are therefore placed at the top level of the menu for quick and easy access. They are also shown on-screen in most preview modes, so you can easily keep an eye on them as you work.

ISO

The CFV can be set to the desired rating according to requirements. Note, however, that the 'natural' sensitivity of the sensor is ISO 50, so you will get best results with this setting if the light conditions allow. Higher ISO settings result in progressively 'noisier' images.

To set the ISO:

1. Select the **MENU > ISO** item. This is the top item of the top menu, so it will be selected by default when you enter the menu system.
2. Use the **+** or **-** button to step through the available ISO settings until the setting you want is shown.
3. Either move on to another setting by using the navigator button or press the menu button to exit the menu system and keep your setting.

White balance / Grey Balance

There are several ways to make a white/grey balance adjustment. When untethered on location you might prefer to make a quick preset adjustment setting at the same time that you check the ISO and Media settings. Tethered in the studio you might prefer to take the first shot of a grey scale and make the adjustment in Phocus for that session.

To select a preset white balance:

1. Press the **MENU** button on the CFV.
2. Use **▲** and **▼** to select the **White Bal:** sub-menu.
3. Use the **+** or **-** button to step through the available choices until the one you want is shown.
4. Either move on to another setting by using the navigator button or press the **MENU** button to exit the menu system and keep your setting.

See following section for how to make a manual white balance setting.

Note

White balance settings are for your viewing convenience only. They in no way affect the raw file which remains 'neutral' awaiting further processing.

There are seven 'White Balance' settings to choose from.

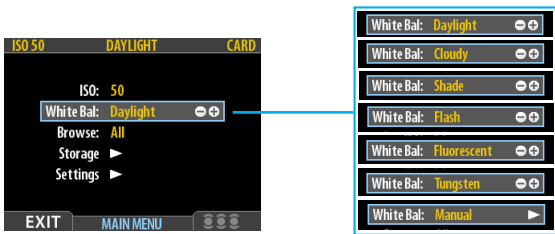

White Bal. Setting	Setting description
Daylight	For general outdoor use in direct sunlight.
Cloudy	For general outdoor use in cloudy weather.
Shade	For general outdoor use in shady locations out of direct sunlight.
Flash	For general indoor use when using a normal flash/strobe system.
Fluorescent	For use when using fluorescent lighting (strip lights).
Tungsten	For use when shooting indoors under standard tungsten/B lamps.
Manual	For a manual setting.

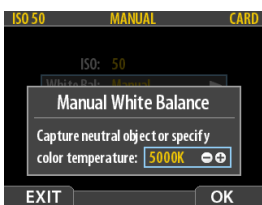

Color temperature can be set manually or read off after a test exposure.

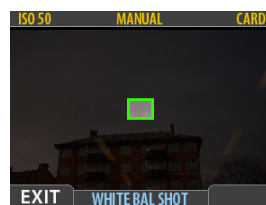

White Balance Shot screen appears after test exposure to illustrate the area chosen for white balance calculation.



To make a manual white balance setting:

1. Select the **MENU > White Bal > Manual** item.
2. Use the **▶** button to call up the 'Manual White Balance' screen.
3. Here, you can adjust the color temperature to a specific numeral setting in degrees K with the **+** or **-** buttons.
Alternatively, you can position the central spot in the viewfinder over an area that you consider should be rendered as neutral in color in the image (a 'grey card' or even a sheet of white paper is ideal) and make a test exposure (ensure the exposure is approximately correct otherwise you will get a warning message). A small rectangle appears on the display marking that particular area. Calculations then take place automatically so that the following shots use the area chosen as the new 'white balance' standard. Using this method you can also read off the screen what the color temperature of the light source has been judged to be in degrees Kelvin.
4. Press the **MENU** button to exit the menu system and keep your setting.

Note

New settings are retained even when the unit has been turned off and reactivated, so don't forget to make new settings when required.

Media (16 & 39 Mpix only)

Media allows you to choose the target medium for file storage. You can choose between a CF card or an ImageBank-II.

Normally though, you have just one type of storage media available. If your selected storage medium has more than one batch (folder) on it, then the batch selected when you use the storage menu item will be the one you most recently created.

To select the target medium:

1. Press the **MENU** button.
2. Select **Media**.
3. Use the **+** or **-** button to choose.
4. Either move on to another setting by using the navigator button or press the menu button to exit the menu system and keep your setting.

Tip

You can select media using just the **+** and **-** buttons while browsing images. This method also enables you to select a batch as you zoom in from media to batch to thumbnails to preview. See *Navigating Media and Batches* for complete details about this method.

Browse

Browse allows you to filter capture previews according to their IAA rating when viewing captures. To start with it might be easier to select **ALL** until you get into the habit of rating individual captures. See later section for full details about IAA rating

To select a Browse setting:

1. Press the **MENU** button.
2. Select **Browse**.
3. Use the **+** or **-** button to choose (in this case, **All**).
4. Either move on to another setting by using the navigator button or press the menu button to exit the menu system and keep your setting.

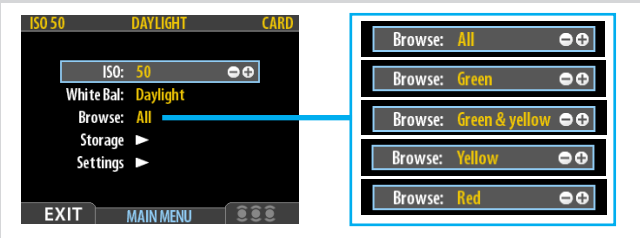

Shortcuts

To help you work faster, the CFV provides shortcuts to some of the most commonly used menu commands that do not otherwise have a dedicated button on the front panel. Try to memorize these quick actions to save time and effort later!



To set the browse filter



Press and hold until your preferred filter is indicated.

See Using Instant Approval Architecture for full details.

To toggle the overexposure indicator



Press and hold **▲** until the display begins to flash (or stops flashing) its overexposed areas.

See Overexposure Indicator for full details.

To delete images



Select the target image and then press and hold **▼** until the delete dialog opens.

See MENU > Delete for full details.

CFV

3

Previews



Photo: Mark Zibert / Hasselblad Masters

Preview Display

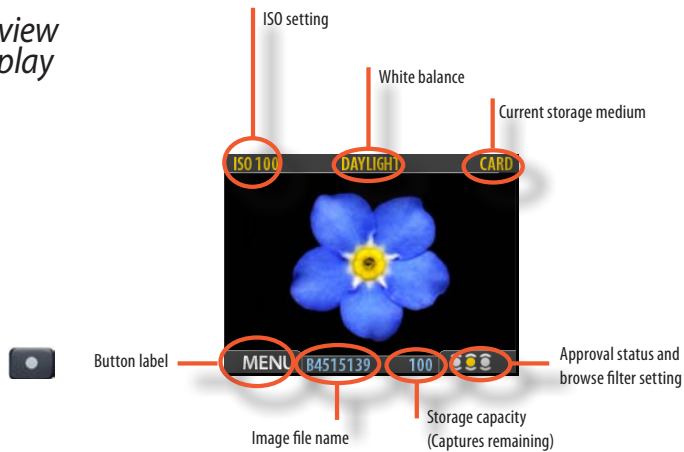

The standard preview display is the one shown when you first turn on the camera and is probably the view you will use most often. It features a preview of your most recent shot and basic information about the settings and the image itself. Several other display modes are also available, including histogram, capture details, full-screen and battery saver. Please see **Preview Modes** for details.

Furthermore, the display enables you to navigate the menu system and make camera settings; see **Working with the Menus** for details.

Preview Modes

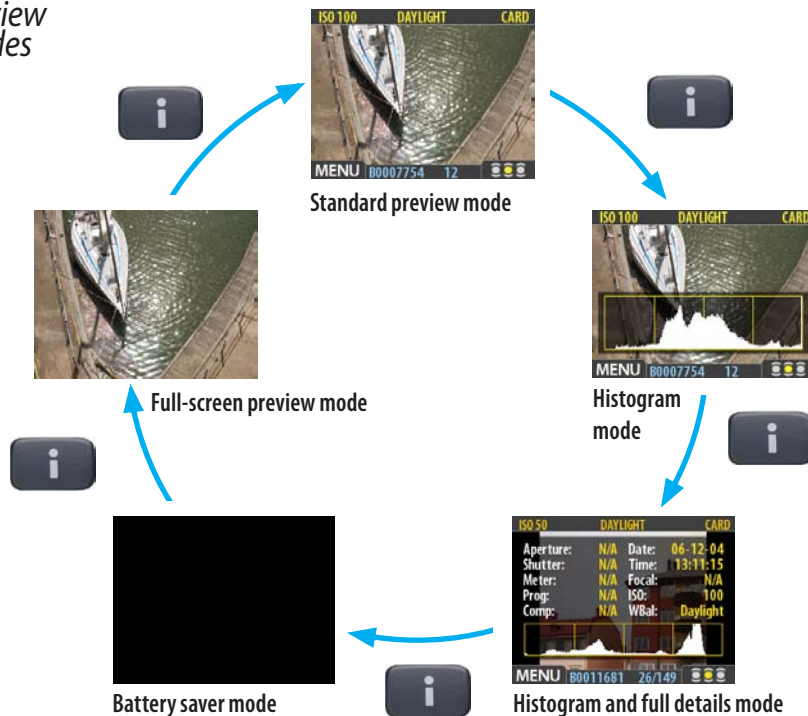

You can cycle through all the available preview modes by pressing the View-Mode button.



View-Mode button

Preview Modes

Choosing the Preview mode

Use the **View Mode** button to cycle through the available preview modes which are:

- Standard preview:**
 Shows a preview image surrounded by a display of a few important settings. Note that the information covers some of the image. Go to Full-screen mode to see whole image.
- Histogram:**
 Shows a preview image overlaid with a histogram.
- Histogram and full details:**
 Shows a preview image overlaid with both a histogram and camera-setting details.

Note

The histogram is only an indicator that should be interpreted—there are situations in which a doubtful histogram will match an exposure that is very good for the intended effect (and vice-versa).

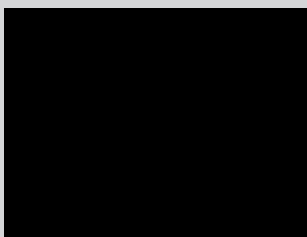
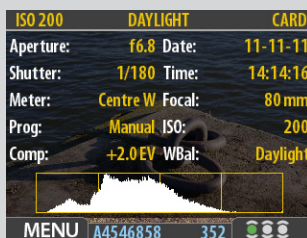

- **Battery saver:**

Turns off the screen, but you can still use the menus and take pictures.

- **Full-screen preview:**

Shows the preview only, with no frame or settings information.

Regardless of the current mode, if you zoom in on the image or zoom out to the thumbnails, the display reverts to showing the “standard” preview frame, which shows information about the current image and camera settings around the edges. When you return to the standard zoom level, however, you will then also return to your last-selected preview mode.

The display also operates in menu mode, which does not show a preview, but enables you to make sensor unit settings. To enter menu mode, press the menu button. See **Menu Items** for details.

Histogram Mode

A, B, C

The histogram provides a graph that indicates the total number of pixels at each brightness level, with brightnesses going from black on the left to white on the right. It is a valuable tool for evaluating your exposure. A well-exposed shot usually has a full range of levels, while under- and overexposed shots tend to show levels concentrated at the left or right part of the scale, respectively.

Underexposure

A

A histogram that is concentrated on the left with few pixels elsewhere indicates a likely underexposure. Many details will be lost in the shadows.

Even exposure

B

A histogram display that is spread across the full range indicates a likely good exposure. There may still be a few pixels at the extremes, indicating a few spectral highlights and saturated shadows, but this is often normal in a good exposure.

Overexposure

C

A histogram that is concentrated on the right with few pixels elsewhere indicates a likely overexposure. Many details will be lost in the highlights

Full-details mode

D

In full-details mode, you can read a complete list of camera settings, plus see the histogram and, in the background, a darkened preview of the image.

The camera-setting details are stored with the image, so you can refer to them using Phocus even after you have loaded the image to your computer and stored it in your archive.

Battery-saver mode

E

In this mode, the CFV is fully responsive, so you can take pictures but the screen is not lit up, thereby saving battery power.

You can enter the menu system while shooting in this mode (which activates the screen until you exit the menu system again) but the approval, zoom and navigator buttons have no effect.



F

1

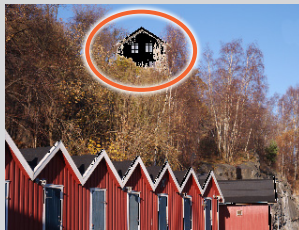

Full-screen mode

F

In full-screen mode, you can browse your images at standard preview resolution without any distracting data surrounding them.

Because the current approval setting is not shown in full-screen mode, the approval button has no effect. This will prevent you from accidentally assigning the wrong status without realizing it.

Overexposure indicator

1

Though the histogram shows you when some of your pixels are overexposed, it does not tell you which ones. In a shot with many bright areas, it can be hard to know whether the key parts of your image are just bright or completely overexposed. To help you find them, the CFV can provide an overexposure indicator, which shows precisely which areas of your shot are overexposed (i.e., pixels that are at maximum brightness, thereby eliminating details).

When enabled, the overexposure indicator flashes the overexposed pixels from black to white.

To enable or disable the overexposure indicator, use the **MENU > SETTINGS > USER INTERFACE > Mark Overexp.** or the shortcut (see below).

Please see **Items on the USER INTERFACE Menu** for a detailed procedure.

Tip

You can save battery power by turning down the brightness and/or contrast of the display using the **Items on the MENU > SETTINGS > USER INTERFACE > DISPLAY** menu. See *Making Display Settings* for details.

Tip

Overexposure indicator shortcut



There is a one-button shortcut for toggling the overexposure marker on and off.

To use it, press and hold ▲ until the indicator is working as you would like (enabled or disabled)

Tip

Ways to save battery power include setting a display time-out and/or a power-down time-out (each of these is disabled by default).

Use **MENU > SETTINGS > USER INTERFACE > Power Down** to set a power-down time out.

Use **MENU > SETTINGS > USER INTERFACE > DISPLAY > Time-out** to set a display time-out.

See also **Items on the USER INTERFACE Menu** and *Making Display Settings* for details about these settings.

CFV

4

Batches & Browsing



Photo: Bang Peng / Hasselblad Masters

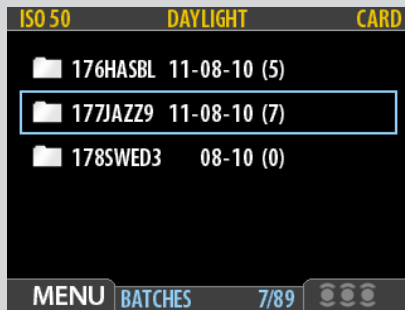

Note

Each new image will be saved in the latest created batch only - the **current batch**. You cannot 'select' a batch for storage.

Batches

When working untethered, captures are stored in named and dated folders called batches on a CF card. They help you to organize your shots as you work and function exactly as folders on a computer.

Batches have the following properties:

- When you create a new batch, you assign a name to it.
- When you copy images from a compact-flash card, each batch is saved as a sub-folder on the destination disk.
- When deleting multiple images, you are able to restrict the delete command so that it affects just a single batch.
- When browsing images, you will only see images from the current batch.
- You can change between batches by using the navigation controls.
- The batch name also shows the date on which it was created (using the Year/Month/Day convention).

Current batch

The camera always works with a **current batch**. This is the location at which the camera will save all new shots and the natural location in which you can browse using the navigator. A newly created batch automatically becomes the **current batch**. You can browse any batch but not reassign them as target folders to store new files.

When tethered, the equivalent of a new batch is automatically created in Phocus.

Batch and Media screen overview

The **BATCH** screen.

The blue frame around a folder tells you that it is the **Current Batch**.

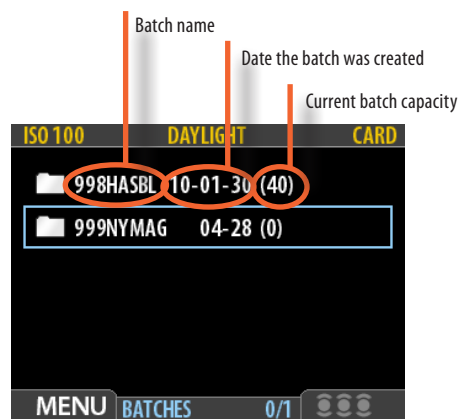

The **MEDIA** screen.

Displays information about the **Current Medium**

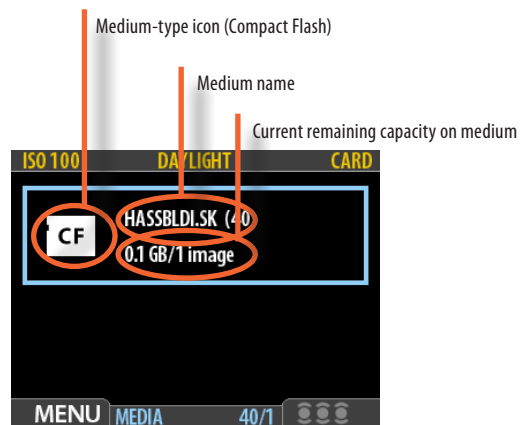

Creating new batches

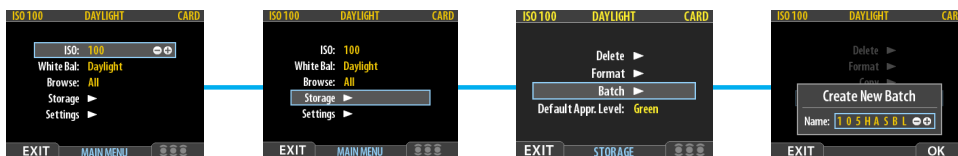

1



2



3



4



5



Creating a new batch

1. Press the **MENU** button.
2. Press **▼** to navigate down and select the **Storage** dialog. Press **▶** and then **▼** to navigate down and select **Batch**.
3. Press **▶** to open the **Batch** dialog. The new batch name will always begin with a three-digit number, which automatically increments by one with each new batch. Following this are five letters, which you can assign yourself to help make the batch easier to identify. To set the letters: Use **◀** and **▶** to select one of the five letters. Then use the **+** or **-** button to step the currently selected letter up or down the alphabet until you have found the letter you want. Continue working until you have set the name you want.
4. Press the approve (**OK**) button to save the new batch with the name you selected.
5. You now return to the **BATCH** menu. Press the menu (**EXIT**) button to exit the menu system.

Browse

The browse filter complements the instant-approval system by enabling you to browse through images according to their approval status. You have the following choices:

- **All:** browses all of the images in the current batch, regardless of their approval status. This is the default.
- **Red:** browses only red-status images from the current batch. These are images that you have marked for likely deletion. You might browse these images to make sure you have not eliminated any usable images and/or to find images that you can delete to make room for new shots.
- **Green:** browses only green-status images from the current batch. These are either new shots that did not trigger an exposure warning or shots that you manually assigned to green after overriding an exposure warning.
- **Green & Yellow:** browses green and yellow-status images, but does not show red-status images. These are probably images that you have either decided to keep or not yet checked for approval status.

For more information about using the instant-approval system, please see [Using Instant Approval Architecture](#).

Tip

Browse shortcut



There is a one-button shortcut for changing the browse filter.

To use it, press and hold (do not click!) the Instant Approval button until the approval status color appears. Browsing will then only display the images with that classification.

Basic image browsing

The display enables you to inspect your shots while you are still on-location. It offers full-screen previews, high-magnification zoom, two levels of thumbnails and analysis tools including a full histogram and camera settings.

When you first turn on the camera, the display opens in standard browse mode, showing the last capture taken (if any) for the current batch. Likewise, after each new shot, the display shows a preview of the capture.



Browsing

To browse the captures in the current batch, simply press the left (◀) and right (▶) arrows of the navigator button.



Zooming buttons

You can use the Zoom in/out buttons to not only view various levels of detail in your images but also view and select batches and media.

Zooming in for more detail

You can zoom very far into the images to inspect small details. To do this:

1. Browse to the image you wish to zoom into with the navigation button.
2. Press the zoom-in (+) button to zoom in one step. The screen updates to show both a zoomed image and a thumbnail image that includes a red frame outlining the portion of the images currently shown.
3. You can now do the following as needed:
 - Use the navigator button to move the zoom area if you wish to inspect a different part of the image.
 - Zoom further by pressing the zoom-in (+) button more times.
 - Zoom back out one step by pressing the zoom-out (-) button.
4. When you are finished, press and hold the zoom-out (-) button to return to browsing at the standard zoom level.



The zoom buttons (+ and -) not only enlarge or diminish images to produce thumbnails but they also navigate to batches and storage medium for selection and inspection. Below illustrates the sequence of events.

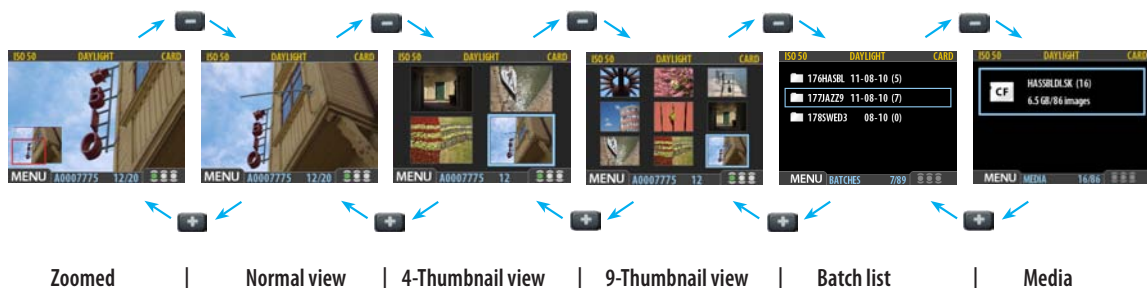

1



2



3





4



Browsing batches

When you browse using the navigator button, you will only see images from the current batch (folder) on the current medium. To view another batch, you must navigate to it by zooming out to the batch level and then zooming in on the appropriate folder.

Selecting another batch to browse:

1. Press the zoom-out () button repeatedly until you are all the way at the top zoom level. If you start with the single-image preview view (as illustrated here), then you pass through the following views to get there: single-image preview > four-thumbnail view > nine-thumbnail view > batch list (as in fig 2)
2. Each batch appears as a folder icon with a name and the date on which it was created. You can read the number of shots that are stored in each batch. Use ▲ and ▼ to highlight the batch you wish to view.
3. The currently selected batch shows a blue border.
4. Press the zoom-in () button to zoom in on the currently highlighted batch. The nine-thumbnail view of your selected batch now appears.

Thumbnail views

Preview thumbnails are small versions of each preview, sized to fit either four or nine images on the screen at once. Use them to get an overview of your work so far and to help find specific shots.

To see the thumbnails, start with the standard preview display and press the zoom-out button once to see four thumbnails or twice to see nine (see illustration in this chapter).

When viewing thumbnails, the selected image shows a blue border. When an image is selected, you can zoom in on it using the zoom-in button or delete it using **MAIN MENU > STORAGE > Delete** (see also **MAIN MENU > STORAGE > Delete** for a detailed procedure). Use ▲ and ▼ to scroll the thumbnails when you have more shots than can be shown.

Viewing modes

Various amounts of information can be displayed when viewing previews. This ranges from histograms to a set of metadata. There are five modes. See **Preview Modes** for details.

Browsing by IAA (approval status)

You can set the camera to browse only images of one or more specific approval levels from a batch. You can use this, for example, to review all of your red-status shots to make sure you don't need them or to review all of your yellow-status shots to decide whether they should be moved to green or red status. When you use the browse filter, you will not see images excluded by the filter, but they are still there.

See next section, **IAA - Instant Approval Architecture**, for complete details about how to check and set the browse filter.

Note

If you continue to zoom out beyond the nine-thumb view, you will come to the batch list and then to the media list. You can use this to select the current batch for browsing and for storing new images.

Tip

You can select batches using just the (+) and (-) buttons while browsing images. This method also enables you to select a batch as you zoom in from thumbnails to preview. See **Navigating Batches** for complete details about this method.

Note

When you browse using the navigator button, you will only see images from the current batch. To view another batch, you must navigate to the media list by zooming and then selecting the appropriate batch.

See **Navigating Batches** for complete details about how to select the current batch.

CFV

5

IAA

**Instant Approval
Architecture**



Photo: Lyle Owerko / Hasselblad Masters



Using Instant Approval Architecture

The Instant Approval Architecture system helps you to evaluate your images as quickly as you take them. It works by supplying immediate audio feedback, which tells you instantly whether each new capture is exposed correctly or likely to be rated as over- or underexposed. Simultaneously, it applies a colored code to each capture as a visual reminder of its status. This status can be manually changed when browsing either immediately or later on. In addition, each file named is prefixed by a letter (A, B or C) according to status. This system also allows you to browse by filtering to show or hide only the captures you want.

The color coding and the name coding remains tagged to the file so when it appears in Phocus, the status can be used by way of filtering to speed up and facilitate the filing, browsing and selection process at that stage too.

Though you can use the system any way you like, the intention (based on the 'traffic light' principle) is that you should assign the levels as follows:

- **GREEN** for your best shots.
- **YELLOW** for images that need closer inspection.
- **RED** for images that you are unlikely to use.

IAA overview

Current browse filter setting
Faster and more effective browsing can be achieved by filtering captures.
The 'brackets' represent the filtering method selected as follows:

- Show all
- Show green and yellow only
- Show green only
- Show yellow only
- Show red only

Current approval status
A coloured dot represents the current approval status. The colour will change if the status is changed.

Capture file name
File names are prefixed by a letter to represent the current approval status. This letter will change if the status is changed. In this example the capture is green so therefore the file name starts with 'A'.

The coding is as follows:

- GREEN** files start with – 'A'
- YELLOW** files start with – 'B'
- RED** files start with – 'C'

Note

There are two different actions concerning the approval button. Quickly clicking will change the status whereas pressing and holding will change the browse filter.

Tip

The default approval level is set by going: **Menu > Storage > Default Appr Level**. See later section for details.

Standard Instant Approval workflow

The standard method of working with the Instant Approval Architecture is as follows:

1. Take a shot.
2. The camera analyses the shot to find out if it seems to be over- or underexposed. If it suspects a problem, it does the following:
 - provides audio feedback (if this option has been chosen) by making a warning sound, which immediately alerts you to a possible problem even if you are not looking at the screen. The warning sound is a rapid string of notes going up the musical scale if the image is judged as overexposed or conversely a rapid string of notes going down the musical scale if the image is judged as underexposed.
 - downgrades the approval status to yellow (if Approval is set to 'Auto').

Note

When the CF card is full, red-status images will be deleted (one at a time) to make room for new shots.

You can continue shooting until no red-status images remain. If you then try to take additional captures, you will get a 'medium-full' message.

Note

Some captures may trigger audio warnings even though they are exposed according to your intentions. You should consider these warnings only as a guideline. This feature can be turned off in User Interface > Sound.

3. If no problem is detected, then the image is saved with the chosen default approval status.
4. When you are browsing through your shots, keep an eye on the approval status of each and consider whether you should promote or demote each shot based on its appearance on the preview screen. You can also apply a browse filter, for example, to browse only red shots when looking for images to delete or to browse only green shots to make sure you have a good version of each shot that you need.
5. When you begin working with the images in Phocus, use the approval status as a guide for organizing your work. For example, you might begin by opening and optimizing the green shots and then go to the yellow shots only if you still need more images and then, finally, check the red shots as a last resort.

Note that the system is very flexible so you can use it in any way that you like. For example, you can set the camera to assign all new images a yellow or green status regardless of the exposure warning. Be careful when assigning red status because red images may be deleted if the current storage medium becomes full.

By keeping an eye on the file name and/or colored dot as you browse your images at the single-image, four-thumbnail or nine-thumbnail level, you can easily see the current approval status of each of them.

To change the approval status of the currently displayed/selected image, simply press the approval button until the desired approval status is shown.

Changing the IAA approval status of individual captures.



Press the approve button to change the status of the currently selected image.

Note

You can set the CFV to filter by approval status as you browse, which means that some images may be hidden (though they are still there). See **Browsing by Approval Status** for details about how to work with the filter.

Note

Be careful when assigning red status because red images may be deleted if the CF card becomes full.

Note

If you set **Approval to Auto**, all images will be stored as Green if judged as correct and Yellow if judged as doubtful. No images are ever stored as Red automatically!

1

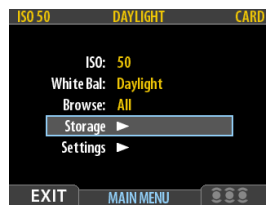

2

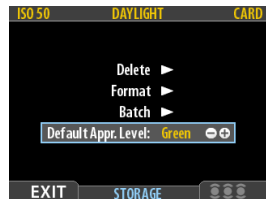

3

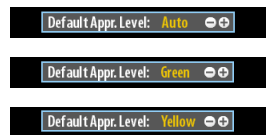

4



Default approval status

By default, the system assigns an initial approval status for each new shot based on an analysis of the distribution of exposure levels. However, you might choose instead to override this system and have all new shots assigned either as green or yellow, regardless of the exposure analysis results. A typical strategy could be to assign all shots to yellow and then review all of the shots later and promote only the best ones to green status. At the same time you might demote the most doubtful shots to red status.

To change the default status assigned to each new image:

1. Press the **MENU** button.
2. Press **▼** to navigate down and select the **Storage** level.
Press **▶** and then **▼** to navigate down and select **Default Appr. level**.
3. Use the **+** or **-** button to step through the available settings until the default status you wish to use is shown:
 - **Auto:** works as described in **Standard Instant Approval Workflow**.
 - **Green:** gives all new images a green status, regardless of the exposure warning.
 - **Yellow:** gives all new images a yellow status, regardless of the exposure warning.
4. Press the menu (**EXIT**) button to exit the menu system and keep the setting.

Note

Understand the difference between changing the **Default Approval Status** (which affects all new captures) and manually changing the **Approval Status** of individual captures.



Show all
(brackets on all)



Show green and yellow only
(brackets on green and yellow)



Show green only
(brackets on green only)



Show yellow only
(brackets on yellow only)



Show red only
(brackets on red only)

Tip

Browse filter shortcut



Press and hold (do not click!) the Instant Approval button until the approval status colour appears. Browsing will then only display the images with that classification.

1



2



3



Browsing by approval status

You can set the camera to browse by approval status, which means, for example, that you will see only green-status images as you browse a batch (or both green and yellow, or only red, etc.). The current filter setting is indicated on-screen, as illustrated. Filtered images are still there, but they will not be shown until you change the filter setting. Also, if you change the status of an image, the image may 'disappear' if it no longer passes the filter. For example, if you have set the camera to browse only green-status images and then change an image to yellow status, that image will not be shown again until you change the browse filter. You have the following choices:

- **All:** browses all of the images in the current batch, regardless of their approval status. This is the default.
- **Red:** browses only red-status images from the current batch. These are images that you have marked for likely deletion. You might browse these images to make sure you have not eliminated any usable images and/or to find images that you can delete to make room for new shots.
- **Green:** browses only green-status images from the current batch. These are either new shots that did not trigger an exposure warning or shots that you manually assigned to green after overriding an exposure warning.
- **Green & Yellow:** browses green and yellow-status images, but does not show red-status images. These are probably images that you have either decided to keep or not yet checked for approval status.

There are many ways to make use of this feature. For example:

- Set the filter to show only yellow images. Then step through each image and decide whether any of them should be promoted to green or demoted red.
- If you are running out of space, set the filter to show only red images and then step through to find shots you can delete.
- Set the filter to show only green images. Then step through to make sure you have at least one good example of each shot that you need.

There are two ways to set the browse filter. Either use the Browse filter shortcut or:

1. Choose **MAIN MENU > Browse**. The current setting is displayed here.
2. Use the zoom ([-] or [+]) button to step through the filter options (described above) until you have selected the filter you wish to use.
3. Press the menu button to exit the menu system and keep the setting.

The appearance of the 'Empty Browse Filter' message signifies that there are no images with that particular approval status.

Tip

You can also delete images by approval status. See following section for details.

CFV

6

Delete Format Copy



Photo: Joao Carlos / Hasselblad Masters

The **Storage** menu provides items for working with storage management and file deletion.



Deleting single images

1. Use the **Menu** button to go to the nine-thumbnail (in this case) view to make an initial search.
2. Use the navigator button to select the image you wish to delete. When you are viewing thumbnails, the selected image has a colored border around it. When you are viewing single images, the selected image is the one currently shown. (You can delete an image either from single image view or from thumbnail view).
3. Select **MAIN MENU > STORAGE**
4. Press **▶** to open the **Delete** dialog.
5. You are now shown a full-size preview of the selected image and asked to confirm the delete (note that the dialog reads "This image"). Press **OK**.
6. You now return to the main menu. Notice that the unwanted image has been deleted and the batch only contains the three remaining images. Press the menu button to exit the menu system.

or:

1. Make an initial search as above.
1. Press the **+** button to reach full-size preview.
2. Use the **Delete** shortcut.

Tip

Delete shortcut



There is a one-button shortcut for deleting single images. To use it, select a target image and then press and hold the **▼** until the confirm-delete dialog opens.

Menus for deleting several images by *Approval Level* from the *CURRENT BATCH*.

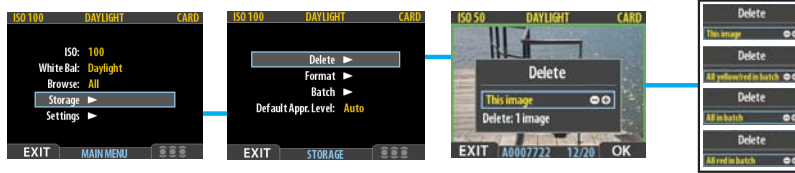

1



2



3

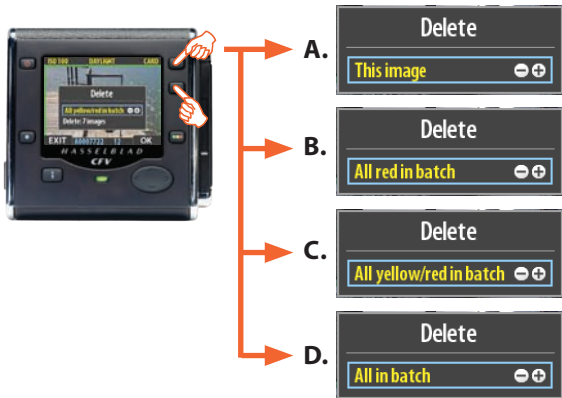

4



5



Deleting by Approval status

To delete several images at the same time using Approval status.

- Starting at the single-image preview display, Select **MENU** > **STORAGE** > **Delete**.
- Use **▶** to enter the **Delete** submenu or use shortcut.
- Use the **-** or **+** button to select:
 - This image** - deletes the current image only
 - All red in batch** - deletes all red images in the current batch
 - All yellow/red in batch** - deletes all yellow and red images in the current batch
 - All in batch** - deletes all images in the current batch
- Press **OK** to confirm the delete (to exit without delete, press **EXIT**).
- You now return to the main menu. Press the menu (**EXIT**) button to exit the menu system.

Note

You will always be asked to confirm each delete operation.

Menus for deleting selected images by *Approval Level* from a *SELECTED BATCH*.

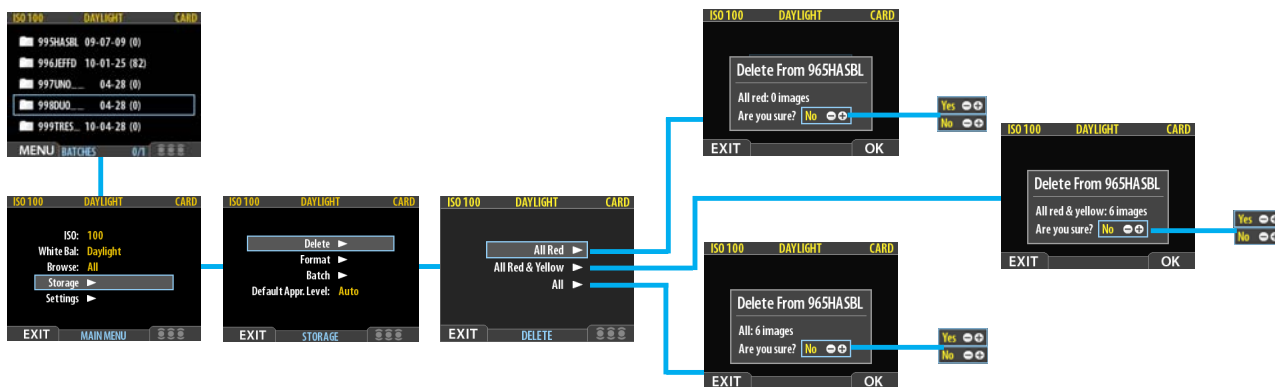

1



2



3



4



6

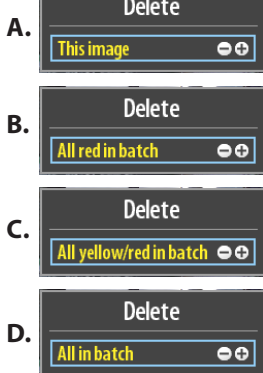

7



8



Deleting several images from a batch

To delete several images at the same time from a selected batch:

1. From a single-image preview display, repeatedly press the **[-]** button until you reach the Batch list.
2. Use the **[OK]** button to select the desired batch
3. Press the **[+]** button to open the Batch then select **MENU > STORAGE > Delete**.
4. Use **[>]** to enter the **Delete** submenu or use shortcut.
6. Use the **[-]** or **[+]** button to select:
 - A. **This image** - deletes the current image only
 - B. **All red in batch** - deletes all red images in the current batch
 - C. **All yellow/red in batch** - deletes all yellow and red images in the current batch
 - D. **All in batch** - deletes all images in the current batch
7. Press **OK** to confirm the delete (to exit without delete, press **EXIT**).
8. You now return to the main menu. Press the menu (**EXIT**) button to exit the menu system.

Tip

Use the delete shortcut immediately after an unwanted capture to save space on a card.

Menus for deleting selected images by *Approval Level* from *ALL* batches on a *CARD*

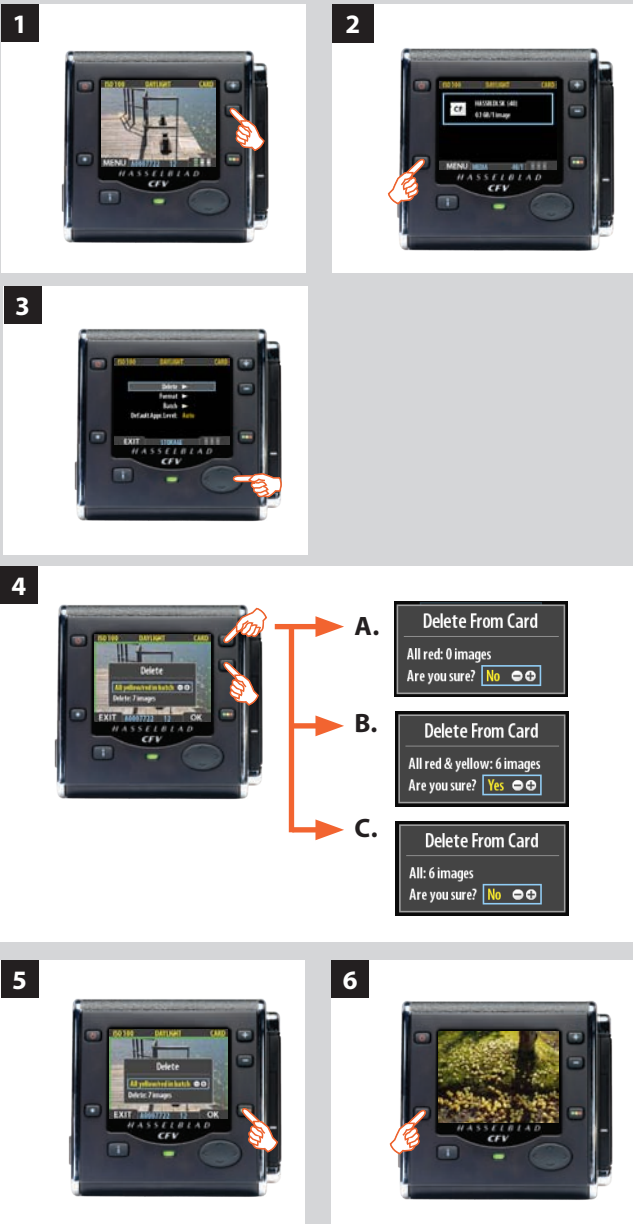
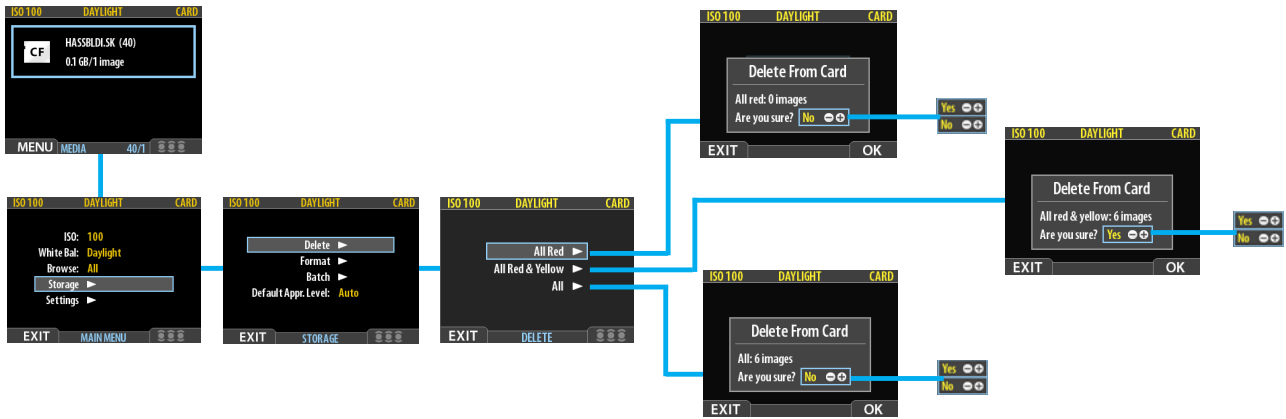

Deleting several images from a CF card

To delete several images at the same time:

- Starting at the single-image preview display, press the **—** button repeatedly until you reach the CF card on the Media screen.
- Press the **MENU** button then select **STORAGE > Delete**.
- Press **▶** to open the **Delete** dialog.
- Use **▲** and **▼** to select the approval status that you wish to delete. All images on the CF card that are the status you select here will be deleted by the operation.
 - All red** - deletes all red files on the card
 - All red and yellow** - deletes all red and yellow files on the card
 - All** - deletes all files on the card

When you have made the selection, press **▶** to open the delete dialog for the selected status.
- Press **OK** to confirm the delete (to exit without delete, press **EXIT**).
- You now return to the main menu. Press the menu (**EXIT**) button to exit the menu system.

Tip

One way of working is to simply assign unwanted images as Red. In this way, you retain the option (for a while) of changing your mind later while allowing the system to automatically delete the unwanted images as the storage medium fills up.

1



2



3



4



5



16 and 39 Mpix models only

FORMAT

The CFV is only able to read and write to media that have been formatted.

However, new cards or disks sometimes arrive without any formatting, or you might want to convert media that are currently using a format that the camera cannot read.

To format media:

1. If you have more than one type of medium connected (e.g., a compact-flash card and ImageBank-II – 16 Mpix only), then start by selecting the medium you wish to format using the **Storage** item of the main menu (see also **Selecting the Current Storage Medium**).
2. Select **MENU > STORAGE > Format**. (See also **Navigating the Menu System** for details about how to find this setting.)
3. Press the **▶** to open the **Format Card** dialog.
4. You are now asked to confirm the operation.
 - To confirm, press the **OK** button. This will carry out the format and delete all data on the CF card.
 - To cancel, press the **EXIT**.
5. You now return to the **STORAGE** menu. Either move on to another setting by using the navigator button or press the menu (**EXIT**) button to exit the menu system.

Note

Each time you get a new compact-flash card, it is recommended that you format it using the CFV as described below, even if the CFV is already able to read it. This will enable the CFV to use the card more efficiently.

Note

The CFV is capable of formatting any type of medium connected to it, including compact flash cards. When you do this, you will erase all data contained on the target medium.

Tip

You can also use the format command for the purpose of deleting all images on a disk. This is sometimes faster than using the delete function, but it is not as flexible because all data from all batches will always be erased.

COPY (16 and 39 Mpix only)

Files can be copied to an ImageBank-II to free up space on a CF card. All batches and files remain on the card until deleted.

To copy files:

With an ImageBank-II attached to the camera by a FireWire cable and turned on:

1. Navigate **MENU > STORAGE > COPY**.
2. Press the **▶** button to initiate the copy process.

CFV

7

Settings



Photo: Nina Berman / Hasselblad Masters

Navigating the USER INTERFACE settings

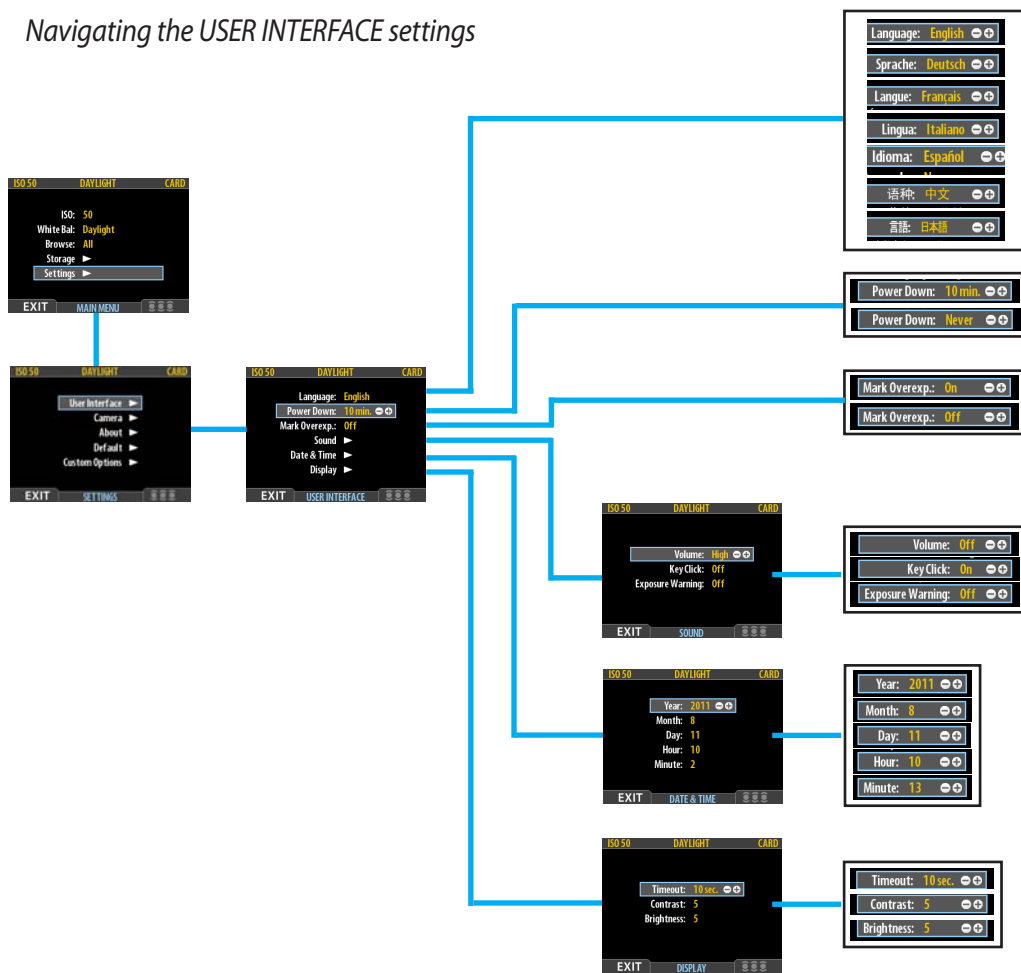

MENU > SETTINGS > User Interface

By altering the **User Interface** settings, you can control the way the CFV interacts to suit you and your preferred way of working. It also includes date and time settings.

USER INTERFACE menu items

The user interface menu includes both items and sub-menus. The following items are available here:

- **Language:**

The menu system can be displayed in any of seven languages. This menu item enables you to select your preferred language for the menus.

- **Power Down:**

To help preserve the charge of the battery, you can set the CFV to power down after a specified period of inactivity. The effect is exactly the same as though you had pressed the off button on the camera. Once it has powered down, you must turn the CFV on again before you can continue working. Set this to **Never** to disable this feature (this is the default setting). Set to a value between 3 and 99 minutes to establish a time-out. (*Note the difference between Display 'timeout' and Power Down.*)

- **Mark Overexp.:**

This feature helps draw your attention to areas of your images that are overexposed. When this feature is enabled, the single-image preview display will highlight each overexposed pixel by flashing it white and black.

Set this item to **On** to enable the feature; set to **Off** to disable it.

- **Sound:**

Audio feedback helps let you know if each new image is exposed correctly. This is described in **Standard Instant Approval Workflow**.

This menu item has **Volume** (choose between **High**, **Low** and **Off**), **Key Click** (choose between **On** and **Off**) and **Exposure Warning** (choose between **On** and **Off**).

- **Date & Time:**

An internal clock keeps track of the date and time. This information is used to mark each shot with the date and time at which it was taken. It is also used to label batches with the date on which each batch was created. (*See note under 'General overview of digital back' about keeping the internal battery charged to maintain Date & Time settings.*)

- **Display:**

This feature sets the Timeout (2-30 seconds) on the display, which behaves very much like a screen saver on a computer. When the timeout is reached, the display will be turned off, but the CFV will still be running, so it will immediately respond to a press of the buttons. (*Note the difference between Display 'timeout' and Power Down.*)

This feature also sets the level of **Contrast** (on a scale of 1-10) on the display. Usually, you should leave this set to the default level of 5, however in some viewing environments and/or with some types of images you may wish to increase or decrease this value. A value of 10 provides maximum contrast; a value of 0 provides no contrast (a black screen). You can also help save battery power by using a low value here.

This feature also sets the **Brightness** (on a scale of 1-10) on the display. This sets the brightness shown on the screen. Usually, you should leave this set to the default level of 5, however in some viewing environments and/or with some types of images you may wish to increase or decrease this value. A value of 10 provides maximum brightness; a value of 0 provides minimal brightness. You can also help save battery power by using a low value here.



Tip

To conserve battery power, change the **Time Out** and **Power Down** settings.

Setting the options under the User Interface menu

Each of the above items can be set by similar menu navigation. Language, Power Down and Mark Overex can be set immediately by the **+** or **-** buttons while Sound, Date & Time and Display require another move to sub menu for final choice.

Proceed as follows:

1. Press the menu (**MENU**) button to open the menu.

2. Use **▲** and **▼** to select the **SETTINGS** sub-menu.

3. Press **▶** to open the **SETTINGS** menu.

4. Press **▶** to select the **USER INTERFACE** sub-menu.

5. Use **▲** and **▼** to select the required item.

Press either the **+** or **-** button to make the new settings in the case of **Language**, **Power Down** and **Mark Overex** or press **▶** again to access **Sound**, **Date & Time** and **Display**.

6. Press the **EXIT** button again to save the new settings and close the menu.

MENU > SETTINGS > Camera

All Hasselblad V-system cameras can communicate with the CFV without the need for extra cable connections except:

- Unmodified 200 series models using CF lenses in C-mode and the FlexBody accessory.

View cameras (with the appropriate adapter and cables) can also be used.

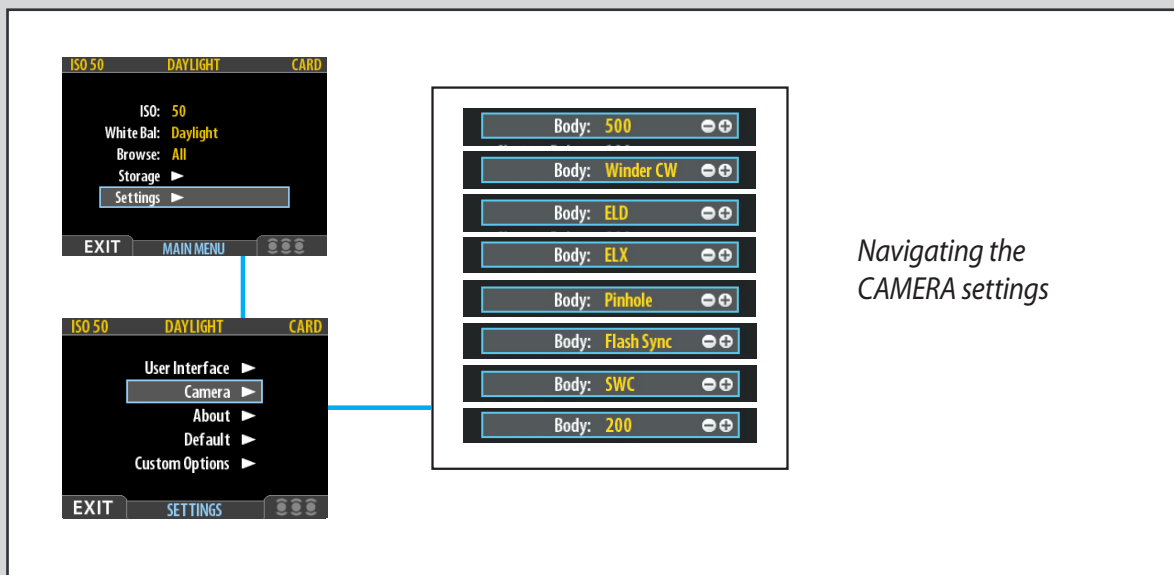

Navigating the
CAMERA settings

Connectivity diagram



CFV digital back

No 'Exposure' cable required

(except for long exposures)



500 C/CM
501 C/CM
503 CX/CXi/CW



SWC / SWC/M
903 SWC
905 SWC

Not recommended for critical use. Please see special note beside the SWC section in this manual.



Modified 202FA/203 FE / 205 TCC / 205 FCC
With F type lenses and CF type lenses at F-mode setting



555 ELD
500 EL/ELM
500/553 ELX



Battery adapter required for portable use.

'Exposure' cable required for control from Phocus

(NOTE: only these cameras/combinations can be controlled from Phocus)



503 CW +
Winder CW



Exposure cable 503 CW required for Phocus control of 503CW + Winder CW.



500 EL/ELM
500/553 ELX



Exposure Cable EL required for Phocus control of EL/ELM and ELX use.



Battery adapter required for portable use.

'Exposure' cable always required



Flash input sync cable



2000 FC / FCM
2003 FCW
201 F / 203 FE
205 TCC / FCC
With C type lenses
(C-mode setting)



FlexBody, ArcBody (Not recommended for critical use).



Any view camera with Hasselblad V system adapter

Note:
For exposures longer than 1/8 second, use the supplied Flash input sync cable. This applies to all models and combinations.

Exposure Cable 503



Hasselblad 503CW plus winder CW

Adapter EL



All Hasselblad EL models

Exposure Cable EL



All Hasselblad EL models except ELD

The exposure time set on the CFV sets the maximum length of exposure. The default setting is 1/8 sec and this is the setting that can be kept for all exposures from 1/8 sec through 1/2000sec. However, this setting should be changed in accordance with the time required if it exceeds 1/8 sec. Times of up to 32 seconds can be set.

If you prefer, you can connect the 'Flash sync input cable' between the lens PC socket and the CFV which allows you to retain the default setting of 1/8 second while still being able to use exposure times longer than 1/8 second. This method also allows the use of the B setting.

Model setting variations

Look in the list below for the camera model you are using and make the appropriate settings change. Don't forget to change the setting if you change camera model!

Winder CW

For use with 503 CW models:

- *Make a Winder CW setting.*
- *If you want to control the camera from Phocus, connect the 'Exposure cable 503' between the CFV and the Winder CW as in the illustration.*
- *Do not use the winder at rapid sequence setting.*

ELD

For use with ELD models:

- *Make an ELD setting.*
- *A B setting exposure can be made by choosing the 'Bulb' in the 'Exposure Time' setting. The maximum exposure time remains at 32 seconds however.*
- *Only the single shot function (A or AS mode camera settings) should be set on the camera. Rapid sequence shots are not possible.*
- *Use the Adapter EL (supplied) to provide the necessary extension beyond the motor housing of the EL models for battery attachment. It is attached to the CFV in the same manner as a battery, and the battery itself is then attached to the adapter as in the illustration.*

ELX

For use with 500EL/ELM and 500/553ELX models:

- *Make an ELX setting.*
- *The Exposure Cable EL (supplied) should be connected.*
- *All exposures times, including the B setting, function correctly without having to alter the "Exposure Time" setting.*
- *Rapid sequence shots are not possible.*
- *Use the Adapter EL (supplied) to provide the necessary extension beyond the motor housing of the EL models for battery attachment. It is attached to the CFV in the same manner as a battery, and the battery itself is then attached to the adapter as in the illustration.*

Pinhole

For use with lenses/cameras with no shutter. Intended primarily for use in a studio environment where complete darkness can be achieved and exposures made accordingly (also useful for 'light painting'). In this mode the CFV uses the exposure time (as well as other required stages in a capture sequence) set in the Capture Sequence dialog. The CFV can be triggered either via the **START** (MENU/EXIT) button or from Phocus (see later section for full description of Capture Sequence settings procedure).

Note

Although the 903SWC and 905SWC models work in conjunction with a CFV, the combination is not recommended for critical work.

The Biogon 38 lens was designed for film use where the unusually close proximity of the lens to the film plane was of no consequence. However, digital sensors and their protective filters make very different demands on the angle and travelling distances of the peripheral rays exiting the rear lens element. Gradual unsharpness consequently occurs towards the edges of the frame, particularly noticeable with flat subjects (typically copying situations, 90° shots against building façades, etc) though these effects will be naturally less obvious with more three-dimensional subjects. Slight green and magenta casts are also caused, though these can be removed digitally in Phocus.

Flash sync

For use with un-modified 200 series models (together with C-lenses in C-mode), a FlexBody or view cameras fitted with a Hasselblad adapter.

- Make a Flash sync setting.
- A Flash sync input cable should be used.
- All exposures times, including the B setting, function correctly without having to alter the "Exposure Time" setting.
- Do not use a winder at rapid sequence setting.

SWC

For use with the 903 SWC and 905 SWC models (not recommended for critical use).

- Make an SWC setting.

PLEASE NOTE: Due to the mechanical design of the SWC, pressing the exposure release button too slowly may cause a faulty capture with a magenta cast. Either press the button much more distinctly or alternatively change the setting from SWC to Flash sync and use the Flash input sync cable to connect the lens to the CFV.

200

For use with modified 202, 203 and 205 models together with F-lenses / CF-lenses in F-mode. (Only these three models can be modified for cable-free compatibility with the CFV/503CWD. Please contact your Hasselblad dealer for further information)

- Make a 200 setting.
- A Flash sync input cable should not be used.
- All exposures times, including the B setting, function correctly without having to alter the "Exposure Time" setting.
- Do not use a winder at rapid sequence setting.

500

For use with 500C/CM, 501C/CM and 503 CX/CXi/CW models.

- Make a 500 setting.

Shutter Delay

There can be differences in the amount of time required in preparation (raising the mirror, opening/closing the shutter etc) for digital capture between various camera models. This corrective feature adjusts the time a little to ensure the image is read out from the sensor. The normal setting is Default and should only be changed if problems are encountered.

Exposure Time

This setting should be changed for cable-free exposure times longer than 1/8 second, ensuring that it matches the set shutter speed/exposure time on the camera/lens. The settings range from 1/8 second to 32 seconds (1/8 second is the default setting). "< 1/8" as seen on the menu list means 'exposures no longer than 1/8 second'. The ELD also has a "Bulb" setting.

Capture Sequence

This feature functions in the same manner as an interval timer and only works in conjunction with a motor or winder driven camera model except in the case of the Pinhole setting where it is the only way of controlling such exposures (see later section for full details).

Initial delay: Controls the amount of time required to elapse before the first exposure.

Delay: Controls the amount of time required between each exposure.

Count: Controls the total number of exposures required.

Setting CAMERA model and options

Proceed as follows:

1. Press the menu (MENU) button to open the menu.
2. Use ▲ and ▼ to select the SETTINGS sub-menu.
3. Press ► to open the SETTINGS menu.
4. Use ▲ and ▼ to select CAMERA.
5. Press ► to open the CAMERA menu.
6. Press either the + or - button to select camera model.
7. Use ▲ and ▼ to select SHUTTER DELAY or EXPOSURE TIME if required.
8. Press either the + or - button to make new settings if required.
9. Press the menu (EXIT) button to exit the menu system and keep your settings.



Setting EXPOSURE TIME and CAPTURE SEQUENCE

Proceed as follows:

1. Press the menu (MENU) button to open the menu.

2. Use ▲ and ▼ to select the SETTINGS sub-menu.

3. Press ► to open the SETTINGS menu.

4. Use ▲ and ▼ to select CAMERA.

5. Press ► to open the CAMERA menu.

6. Press either the + or - button to select PINHOLE.

7. Press ▲ or ▼ to select EXPOSURE TIME.

8. Press either + or - to make an exposure time setting.

9. Press ▼ to select CAPTURE SEQUENCE.

10. Press ► to open the CAPTURE SEQUENCE menu.





11. Press either the **+** or **-** button to make an INITIAL DELAY setting.

This setting controls the amount of time that elapses before the first exposure in the sequence.

12. Press **▼** to select DELAY.

13. Press either **+** or **-** to make a DELAY setting.

This setting controls the amount of time between each exposure in the sequence.

14. Press **▼** to select COUNT.

15. Press either **+** or **-** to make a COUNT setting.

This setting controls the number of exposures in the sequence.

16. Press OK to confirm all the settings.

17. The unit is now ready for sequence start. Note that the MENU/EXIT button now displays START instead:

18. Press START to set the sequence running.

19. Note that the MENU/EXIT button now displays STOP. The sequence can be stopped at any time by pressing this button and the standard menu display returns.

1

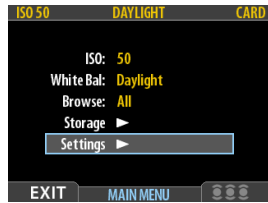

2



MENU > SETTINGS > About

Occasionally, Hasselblad releases updates to the internal software ("firmware") of the CFV. These updates may fix small errors and/or add new features. If you need assistance from Hasselblad technical support it facilitates the situation to know the serial number and current firmware version of the unit. To find this out:

1. Select **MENU > SETTINGS > ABOUT**. (See also *Navigating the Menu System* or details about how to find this setting.)
2. Press **▶** to open the **About** dialog, which shows the serial number and firmware version. When you are done reading the information, press the menu (**EXIT**) button to return to the **SETTINGS** menu. Either move on to another setting by using the navigator button or press the menu (**EXIT**) button again to exit the menu system.

1

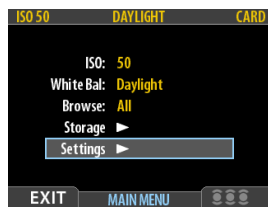

2

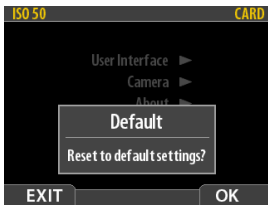

MENU > SETTINGS > Default

The **DEFAULT** setting will reset all custom settings you have made back to the original default / factory settings.

To reset all settings:

1. Select **MENU > SETTINGS > DEFAULT**.
2. Press the **OK** button and then the **EXIT** to return.

Custom Options for 16, 39 & 50 Mpix models



Custom Options selected
(all models)

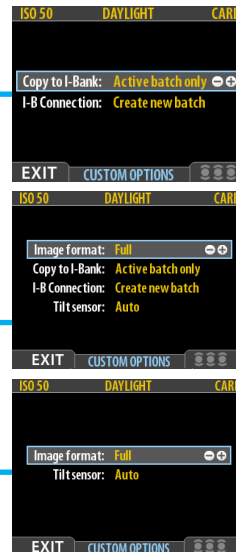

16 Mpix model choices

39 Mpix model choices

50 Mpix model choices

1



2



3

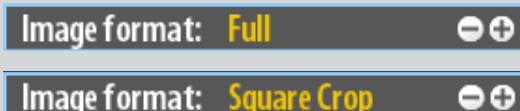

MENU > SETTINGS > Custom Options

Custom Options allow you to make individual settings for the different models:

Image Format (39/50 Mpix only)

Tilt sensor (39/50 Mpix only)

Copy to I-Bank (16/39 Mpix only)

I-B connection (16/39 Mpix only)

Image Format (39/50 Mpix only)

This function allows you to choose the capture format, namely, 'Full' or 'Square Crop'. Full produces a rectangular format of 36.7 x 49.1 and Square Crop, a square format of 36.7 x 36.7.

Captures made at the Full setting will, in normal orientation, appear on the display and in Phocus as 'Landscape' oriented rectangular images. Captures made at the Square Crop setting will appear on the display and Phocus as cropped images, marked with an icon. These captures are also full but are tagged to produce a cropped square format. Naturally, you can retain this cropping in Phocus but if you wish, you can move it or even remove it to reveal the full image again. This facility might be advantageous for those who prefer the square format but who would like the option to adjust the exact placing at the editing stage.

In normal orientation, the cropped areas are to the left and right but if the camera is tilted 90° for capture, you will then have the opportunity to edit at the top and bottom instead, as captures will now be saved and appear in 'Portrait' mode.

To choose between Full and Square Crop:

1. Select MENU > SETTINGS > CUSTOM OPTIONS.
2. Press the ▼ button to reach: Image format:
3. Press either + or - to choose between:
Full or
Square Crop
4. Press EXIT to save.

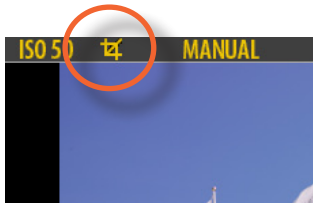

Square Crop icon as it appears on the CFV display.

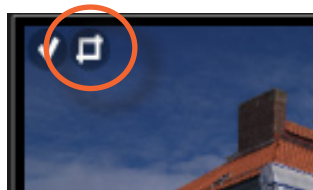

Square Crop icon as it appears in Phocus

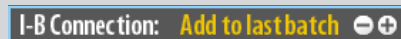
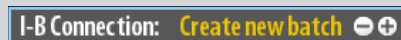

Tilt sensor (39/50 Mpix only)

The tilt sensor tags image files according to the orientation of the camera at the time of capture to ensure correct orientation on the display and in Phocus. There may be occasions when this is not required – when the camera is pointing straight up or down, for example – and so the tilt lock can be set at various degree settings.

1. Select **MENU > SETTINGS > CUSTOM OPTIONS**.
2. Press the **▼** button to reach: **Tilt sensor:**
3. Press either **+** or **-** to choose between:
Auto or
Lock at 0 degrees, Lock at 90 degrees, Lock at 180 degrees and Lock at 270 degrees.
4. Press **EXIT** to save.

Copy to I-Bank (16/39 Mpix only)

Allows you to create new batches or add files to the last batch (on an ImageBank-II).

1. Select **MENU > SETTINGS > CUSTOM OPTIONS**.
2. Press the **▼** button to reach: **Copy to I-Bank:**
3. Press either **+** or **-** to choose between:
Entire card or
Active batch only
4. Press **EXIT** to save.

I-B Connection (16/39 Mpix only)

Allows you to create new batches or add files to the last batch (on an ImageBank-II).

1. Select **MENU > SETTINGS > CUSTOM OPTIONS**.
2. Press the **▼** button to reach: **I-B Connection:**
3. Press either **+** or **-** to choose between:
Create new batch or
Add to last batch
4. Press **EXIT** to save.

CFV

8

Cleaning



Photo: Dirk Rees / Hasselblad Masters



Note

WARNING!

Never attempt to remove the glass filter from the front of the CCD—you will probably ruin the CCD if you do so. If dust manages to get between the IR filter and CCD, please contact your Hasselblad dealer for assistance.



Note

Do not use same side of the e-wipe twice as you will be likely to reapply any particles removed in the first pass.

Removing and attaching the CFV

1, 2

When removing the CFV from the camera (or protective cover from the CFV), hold down the lock safety button while sliding the lock button as in illustration 1.

When attaching the CFV to the camera (or the protective cove to the CFV), repeat the procedure as in illustration 2. Avoid trying to just 'snap' the CFV or protective cover into place without using the buttons.

Cleaning the CCD Infrared Filter

If you see dark or colored spots or lines in your images, then you may need to clean the outer surface of CFV's infrared (IR) filter. In most cases, the careful use of compressed air will be adequate, but sometimes small particles will get stuck to the surface of the IR filter, requiring for a more thorough cleaning, involving either fluid or wipes. For a good safe cleaning, follow descriptions below.

Basic cleaning procedure

1, 2

1. Discharge any static electricity that may have built up on your body by touching the CFV housing.
2. While keeping the lock safety button depressed, slide the lock button to the right.
3. The top of the CFV will be released (while it rests on the magazine retaining hooks) and it can be swung away from the camera body.
4. Clean the outside surface of IR Filter by spraying it with clean compressed air. If this is not enough, then use one of the procedures outlined below.
5. If you still see spots on your shot after you have cleaned the outside of the infrared filter, then you may have dust on either on the inside of the IR filter or on the CCD itself. This can only be removed at the Hasselblad factory. Contact your Hasselblad dealer for assistance.
6. When reattaching the CFV to the camera, keep the lock safety button depressed and the lock button to the right. Check that the CFV is firmly in place.

Cleaning with an E-Wipe

E-wipes are individually packed wet tissues.

1. Tear at the notch to break seal.
2. Remove e-wipe from its packaging and continue without delay.
3. Fold the tissue to match the width of the IR filter.
4. Apply firm pressure using two or three fingers at the edge of the wipe to ensure an even, firm contact with filter surface. Wipe the surface in one unbroken motion.

Cleaning using HAMA Cleaning Fluid 5902 and tissues

1. Carefully spray the fluid onto the IR filter at a distance of 10-15 cm (4-5 inches), so that the fluid is applied onto the filter as a thin, even haze. 1-2 sprays are enough. If you apply too little, the fluid will start to dry up before you start wiping the filter. As an alternative you can spray the fluid onto the tissue first, and then apply it to the filter as you wipe it.
2. Fold the tissue several times to match the width of the IR filter using two or three tissues at a time if necessary (glossy side facing outward).
3. Using two or three fingers, wipe the entire surface evenly (only once). Do not wipe the same area twice with the same tissue.

Cleaning the housings

If the camera becomes dirty, clean it with a soft, clean cloth lightly moistened with water only. Do not use any other solvents and do not allow water to seep in the openings.

CFV

9

Appendix



Photo: Mark Holthusen / Hasselblad Masters

Technical specifications — CFV

	16 Mpixels	39 Mpixels	50 Mpixels
Sensor size	16 million pixels	39 Mpixels (5412 x 7212) 29 Mpixels (5412 x 5412)	50 Mpixels (6132 x 8176) 38 Mpixels (6132 x 6132)
Sensor dimensions	36.7 x 36.7 mm	36.7 x 49.1 / 36.7 x 36.7 mm	36.7 x 49.1 / 36.7 x 36.7 mm
Lens factor with V camera	x1.5	x1.1	x1.1
4 GB CF card holds	720 images on average	80 images on average	60 images on average
Capture rate	35 captures per minute	39 captures per minute 1.4 sec./capture.	33 captures per minute 1.1 sec./capture.
ISO speed range	50, 100, 200, 400	50, 100, 200, 400, 800	50, 100, 200, 400, 800
Longest shutter speed	32 seconds	64 seconds	64 seconds
Shooting mode	Single shot		
Multi shot upgrade	Not available		
File format	Lossless compressed Hasselblad 3F RAW		
Image storage	. CF card type II . computer disk when tethered		
Software	Phocus (included)		
Color definition	16 bit		
Dynamic range	12 f-stops		
Color management	Hasselblad Natural Color Solution		
DAC digital lens correction	Support for DAC for Carl Zeiss lenses included in Phocus		
Color display	TFT type, 2.5 inch		
IR filter	Mounted on CCD sensor		
Battery power	Li-ion 8.4 v		
IAA - Instant Approval Architecture . Histogram analysis . Acoustic feedback	Included, with: yes yes		
Computer support	Macintosh: OSX 10.6. PC: Windows XP / Vista / 7 (32 and 64 bit)		
Host connection	FireWire 800 (IEEE1394b)		
Operating temperature	0 – 45 deg. C / 32 – 113 deg F		
Weight / Dimensions	530 g (excluding battery and CF card) / 91 x 90 x 61 mm (W x H x D)		
Camera support	All Hasselblad V System cameras manufactured since 1957. 2000 cameras and 201F with C lenses only. 202FA / 203FE and 205FCC camera types need a minor camera modification to use F/FE lenses. The ArcBody is not compatible. SWC/M and newer can be used but has limitations on image quality due to lens design not being suitable for digital capture. All other cameras with Hasselblad V interface.		

Equipment care & Service

EQUIPMENT CARE

- Keep all equipment and accessories out of the reach of small children.
- Do not place heavy objects on the equipment.
- Do not use the batteries except as specified.
- Use only the batteries specified for use with the 503CWD and CFV.
- Remove the batteries when cleaning the camera or if you intend to leave it unused for a long period.
- If you use spare (standard or rechargeable) battery packs be particularly careful to use the supplied protective cap when storing. There is a potential fire risk if the contacts are short circuited across a conductive object (such as keys in a pocket, for example).
- Take particular care when working with strobe / studio flash units to prevent damage to equipment and personal injury.
- Do not attempt to open the CFV.
- Always replace the protective cover when the CFV is not mounted on the camera.
- Do not touch the exposed sensor filter with your fingers.
- Ensure that the databus connections are not damaged or soiled in any way.
- Keep all foreign objects out of the 503CW and CFV openings.
- Keep the original shipping boxes for storage.
- Keep your 503CWD or CFV and all other computer equipment away from moisture. If your 503CWD or CFV becomes wet, disconnect from power and allow it to dry before attempting to operate again.
- Never cover the ventilation openings on the 503CWD or CFV when in use.
- Never try to remove the glass IR filter from the front of the sensor; this will probably ruin the sensor. If dust manages to get between the sensor and IR filter, please contact your Hasselblad dealer for assistance.
- Avoid frequent and severe temperature changes and be particularly careful in humid environments. Allow the equipment to acclimatize whenever possible before use. Try to ensure the storage conditions in such environments are as dry as possible.
- Prevent dust and grit from getting into your equipment. In coastal areas take measures to protect your equipment from sand and salt water spray.

- Avoid physical shocks to the 503CW and CFV. Some form of protective case or camera bag is advised for transportation.
- Hasselblad equipment is much sought after and you should take obvious steps to prevent theft. Never leave it visible in an unattended car, for example. Separate and specific camera insurance cover should be considered by professional users.

SERVICE

Return your equipment to a service centre for occasional checking and preventive maintenance to ensure optimal reliability.

DISPOSAL

If you need to dispose of a 503CW, CFV or batteries, please do so in an environmentally friendly manner at the local waste plant/ recycling centre or similar.

Disposal of Waste Equipment by Users in Private Households in the European Union



This symbol on the product or on its packaging indicates that this product must not be disposed of with your other household waste. Instead, it is your responsibility to dispose of your waste equipment by handing it over to a designated collection point for the recycling of waste electrical and electronic equipment. The separate collection and recycling of your waste equipment at the time of disposal will help to conserve natural resources and ensure that it is recycled in a manner that protects human health and the environment. For more information about where you can dispose of your waste equipment for recycling, please contact your local city office, your household waste disposal service or the retailer where you purchased the product.

Further reading

World class results are possible with Hasselblad equipment, witnessed by so many front covers, international advertising campaigns, famous portraits, historical events, etc. But it is the combination of this fine equipment and the abilities of the photographer that produce memorable images. Some of this skill is just sound photographic practice and sometimes it is product specific. The following books are recommended for those that wish to immerse themselves in the world of Hasselblad. The information in them varies from general interest to completely invaluable.

“The Hasselblad Manual” (Seventh edition) by Ernst Wildi. Published by Focal Press — ISBN-10: 0240810260 / ISBN-13: 978-0240810263.

Contains all the information you need to know about the operation of the analogue Hasselblad camera systems, including both recent and earlier equipment.

Also contains excellent general practical photographic advice. Written by a world-renowned lecturer on the Hasselblad system and its practical application. A book for the practising Hasselblad photographer.

“Hasselblad System Compendium” by Richard Nordin — ISBN 978-0-9869188-0-3. www.cloakhill.com/www.hasselbladcompendium.com.

A complete round up of the history of all Hasselblad products up to and including the H4D. Contains photos and descriptions of rare items long since out of production. A mine of information for those interested in a chronicle of the company and the development of its products. It contains a unique collection of dates, lists and almost anything you would want to know about the history and background of Hasselblad equipment. A book more for the Hasselblad collector or as an informational source for used equipment.

Quick Index

503

Accessory rail	11	Pre-release and cable release	15
Aperture	13	Rear cover MultiControl	25
Attaching the lens	13	Removing the lens	14
Attaching the magazine	19	Shutter speed	13
Built-in magnifier	10	Strap attachment and removal	11
Changing the focusing hood or viewfinder	17	Technical specifications	27
Changing the focusing screen	17	Troubleshooting	27
Changing the magnifier	17	Viewfinder indicator	22
Depth of field preview	17	Warning mark	14
Double exposure with film	21	Winding crank	11
Exposure values	14		
Film loading	20		
Film plane position	21		
Film tab holder	21		
Flash adaptor SCA 390	22		
Flash/strobe synchronization	15		
Flash/strobe with film	22		
Focusing and depth of field	14		
Focusing hood	10		
Focusing screen	10		
Front protective cover	10		
Infrared	21, 23		
Interlocked shutter speed /aperture	14		
Magazine status indicator	20		
Parts & components	7		

CFV

Attaching and removing back	36	Histogram mode	53
Batches	72	Image format (39/50 Mpix only)	85
Battery	34	ImageBank-II	44
Battery warning	36	Instant Approval Architecture	60
Battery-saver mode	53	ISO	48
Browsing	56	Media (16/39 Mpix only)	49
Browsing by IAA (approval status)	58	Menu language	47
Capture destination	43	Navigating batches	73
Capture sequence	79	Organizing your work with batches	56
Cleaning	88	Overexposure	53
Compact flash memory cards	45	Overexposure indicator	54
Connecting to a computer	46	Parts, components & control panel buttons	32
Copy to I-Bank (16/39 Mpix only)	86	Preview Modes	52
Creating a new batch	72	Setting camera model and options	80
Current batch	56	Shooting with Phocus running	46
Custom Options	85	Studio flash/strobe units when tethered	37
Default approval status	62	Technical specifications	90
Deleting by Approval status	66	Tethered to a computer	46
Deleting several images from a batch	67	Thumbnail views	58
Deleting several images from a CF card	68	Tilt sensor (39/50 Mpix only)	86
Deleting single images	65	Underexposure	53
File storage	43	White balance / Grey Balance	48
Formatting CF cards and other media	45	Zooming in for more detail	57
Full-details mode	53		
Full-screen mode	54		

The information in this manual is furnished for informational use only, is subject to change without notice, and should not be construed as a commitment by Victor Hasselblad AB & Hasselblad A/S.

Not all the images in this manual were taken with a Hasselblad 503CW or CFV. They are used for illustrative purposes only and are not intended to represent the image quality produced by a Hasselblad 503CW or CFV.

The text in this manual cannot be reprinted or reused without the express permission of Victor Hasselblad AB & Hasselblad A/S.

The images in this manual cannot be reprinted or reused without the express permission of the photographers who took them.

All text in this manual :

© Victor Hasselblad AB & Hasselblad A/S.

Unless otherwise stated, all images in this manual :

© Jens Karlsson, David Jeffery and Ove Bengtson.

Victor Hasselblad AB & Hasselblad A/S assumes no responsibility or liability for any errors or inaccuracies that may appear in this manual.

Victor Hasselblad AB & Hasselblad A/S assumes no responsibility or liability for loss or damage incurred during or as a result of using Hasselblad software or products.

Hasselblad, Imacon, Ixpress, FlexColor and Phocus are trademarks of Victor Hasselblad AB & Hasselblad A/S. Adobe and Adobe Photoshop are trademarks of Adobe Systems, Inc. Macintosh, Mac OS and FireWire are registered trademarks of Apple Computer, Inc. InfoLithium is a registered trademark of Sony Corporation.

Copyright © 2011

Victor Hasselblad AB & Hasselblad A/S

All rights reserved.

Hasselblad A/S
Hejrevej 30, DK - 2400 Copenhagen,
Denmark

Victor Hasselblad AB
Box 220, SE - 401 23 Göteborg,
Sweden