

H A S S E L B L A D **ArcBody**



Instruction manual

Hasselblad ArcBody – *a new way of thinking*

Thank you for choosing the Hasselblad ArcBody. You can now practise the philosophy that lies behind it, breaking new ground with the opportunities that are open to you. This powerful and versatile camera is a broadening of the revolutionary thinking that created the Hasselblad FlexBody. The generous shift capabilities naturally place it first choice for architectural and industrial photography, though in practice the list easily includes product, landscape, portrait photography and a surprising number of other photographic fields too. Essentially a problem solving camera, the Hasselblad ArcBody is also a very resourceful creative tool, producing a broader spectrum of image variations and effects than conventional medium format cameras.

The creative possibilities brought about by the ArcBody can be a new chapter for those more used to conventional medium format photography. Image shaping and other effects can be used to creative advantage, often adding a winning edge over comparable images. In this way the ArcBody can be seen as a double investment, not only by solving problems but also by providing additional creative input into image making.

The rear standard shift of as much as 28 mm ensures the virtual elimination of diverging or converging lines in the image in standard practice, which is a point of major importance in architectural and industrial photography. The rear standard tilt of $\pm 15^\circ$ provides the often much needed extra control concerning depth-of-field. Together they produce results normally only associated with bulky and awkward systems.

The extensive shift facility is permitted by the large image circle produced by the three interchangeable lenses: the Rodenstock Apo-Grandagon 4.5/35, Rodenstock Apo-Grandagon 4.5/45 and the Rodenstock Grandagon-N 4.5/75. These superb optics are supplied complete with accessories to maintain their superb high contrast, colour saturation and even coverage. The combination filter holder, for example, is a valuable asset that ensures a smooth and rapid working method. The lens shutters provide flash synchronization at all shutter speeds.

To produce the bright viewfinder image – a standard requirement on all Hasselblad cameras – the ArcBody uses an ingenious patented focusing screen system incorporating an Acute-Matte D screen. This ensures image clarity virtually regard-



less of the amount of shift or tilt. The Hasselblad RMfx viewfinder is particularly recommended, providing both a vertically correct image and a comfortable working position. All other Hasselblad viewfinders are also compatible, including prism viewfinders.

All Hasselblad film magazines are compatible with the ArcBody, thus providing you with a wide choice. 6x6 cm and 6x4.5 cm formats are catered for, 120, 220 and 70 mm perforated film types as well as Polaroid type instant films.

The ArcBody serves equally well as a main camera or as an extra versatile tool. It is rugged enough to be used professionally on a daily basis yet compact and light enough to be included as an extra resource on all assignments. The ArcBody shines as a stunning example of a professional, superbly crafted and reliable camera capable of producing extremely high quality and original images.

The ArcBody is very easy to use. Its plain, solid construction offers a no-nonsense method of working. This instruction manual describes the operations in detail and covers most questions that should arise from the camera's use. Please read it carefully and keep it with the camera at all times for reference.

The manual assumes a certain familiarity with camera handling and a moderate level of photographic knowledge. Operational details therefore specifically describe the ArcBody, but also include general descriptions of the ArcBody in practice. The numbers in grey boxes in the text refer to the appropriate illustrations in the accompanying manual. If you have a query then feel free to contact your Hasselblad dealer – we want you to be 100% satisfied!

The knowledge gained from this manual will give you full access to the Hasselblad ArcBody potential. Exploiting the potential is left to your imagination!

Welcome to the new Hasselblad ArcBody way of thinking!



Contents

- 2 Introduction
- 4 Contents
- 6 Illustrations
- 26 Parts and components
- 26 ArcBody and supplied accessories
- 27 Optional accessories
- 29 Getting started
- 29 Front protective cover
- 29 Rear cover MultiControl
- 29 Attaching a lens
- 29 Removing a lens
- 29 The viewing system
- 29 The focusing screen adapter and correction slides
- 30 The focusing screen adapter
- 30 Fitting correction slides
- 31 Stray light protection slide
- 31 Viewfinders
- 32 Light metering with a meter prism viewfinder
- 32 Lenses
- 33 Viewing
- 33 Focusing
- 33 Shutter
- 33 Aperture
- 33 Depth-of-field
- 33 Flash synchronization
- 34 Filter Holder
- 34 Filter holder operation
- 35 Lens shade adjustment
- 35 Film Magazines
- 35 Attaching a magazine
- 36 Magazine slide holder
- 36 Film advance
- 36 Removing a magazine
- 36 The magazine status indicator
- 36 Film plane position
- 37 ArcBody movements
- 37 Shift
- 37 Tilt
- 38 Close-up photography
- 38 Bellows
- 38 Exposure sequence
- 40 Camera movements in practice
- 41 Shift examples
- 42 Tilt examples
- 43 Creative examples – shift and tilt
- 45 Troubleshooting
- 46 Technical specifications
- 47 Equipment care, service and guarantee



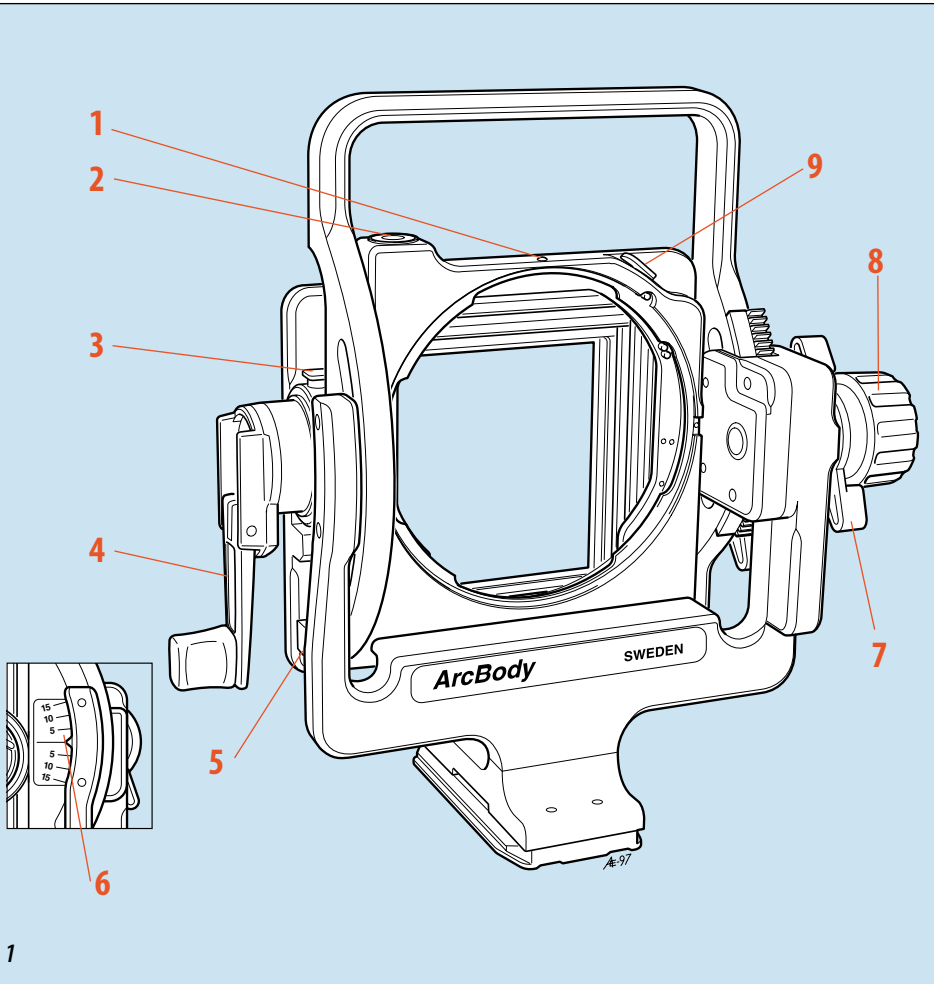

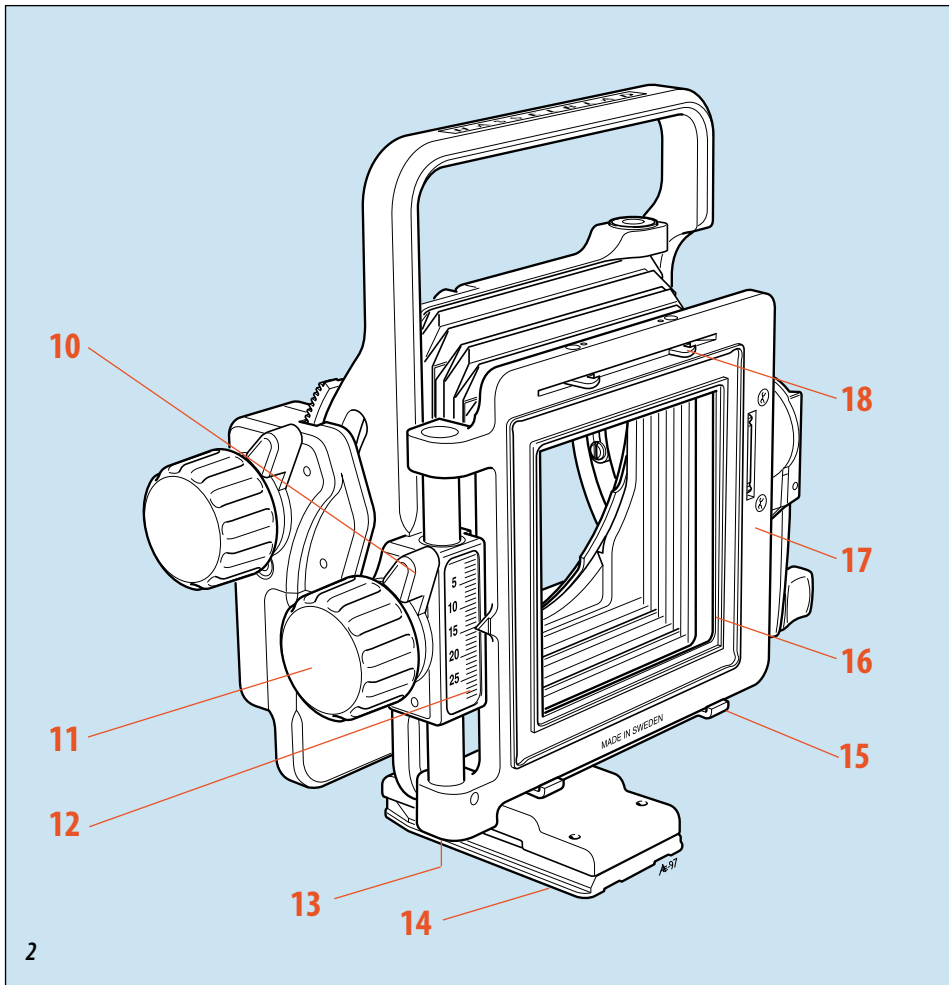

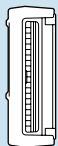
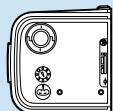
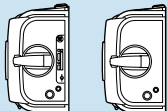

47070

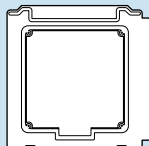
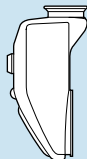
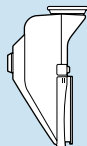
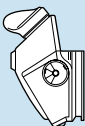
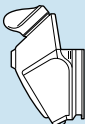

51070

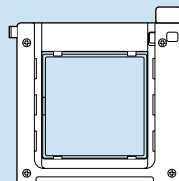

41057

47003



47007



47011



72411



72413



72415





57689

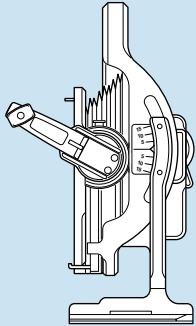

47033

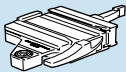

47040



47045

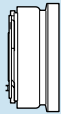

47049

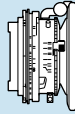

27035

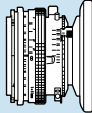

27045

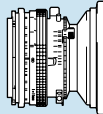

27075



47018

47057

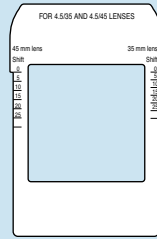

47024

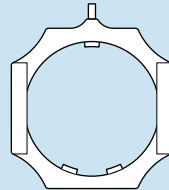

57695

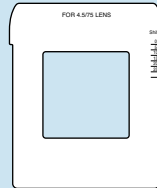

47027

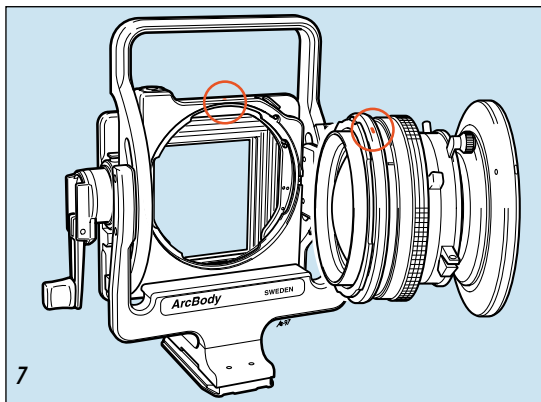
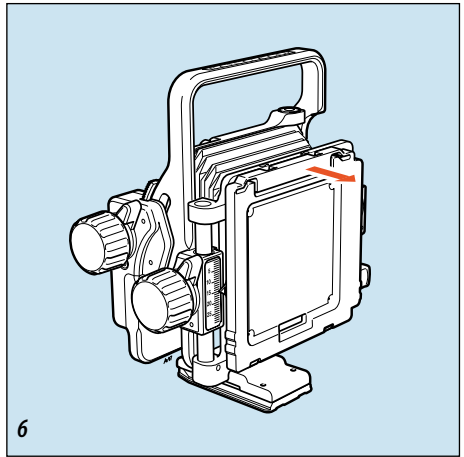
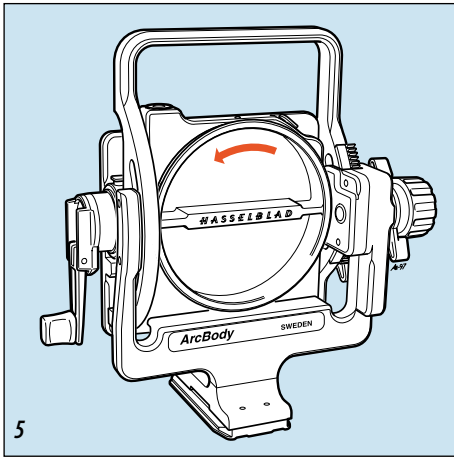

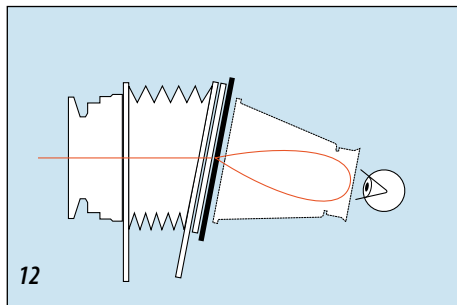
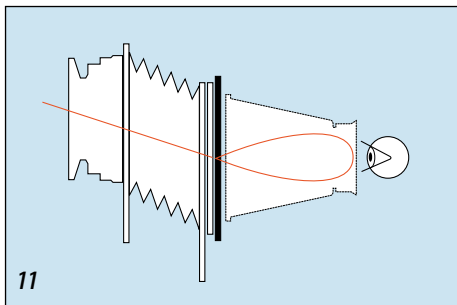
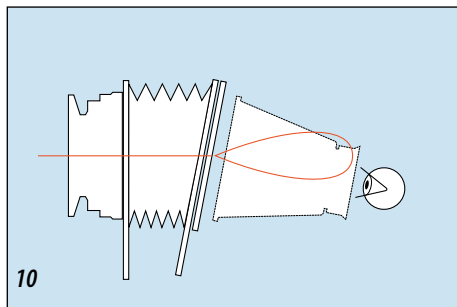
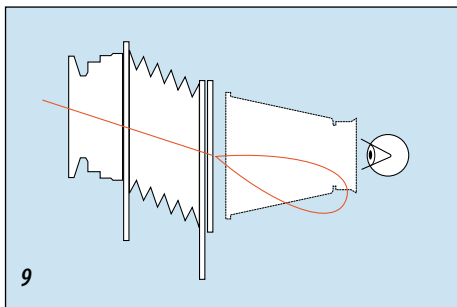
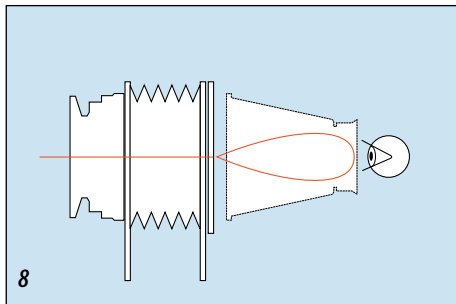

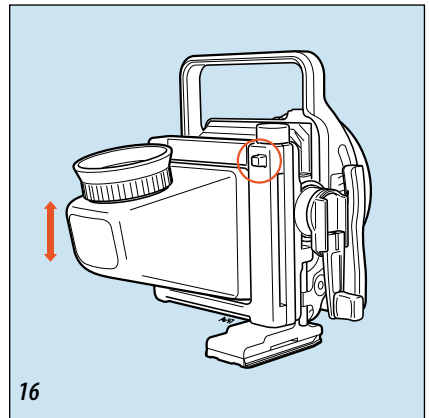
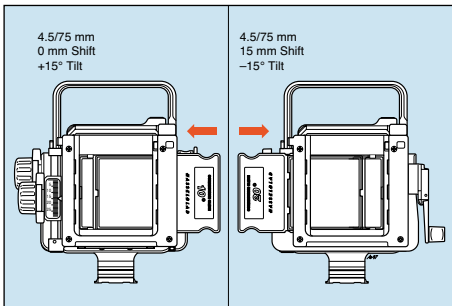
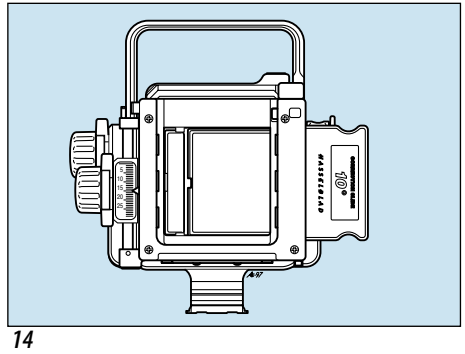
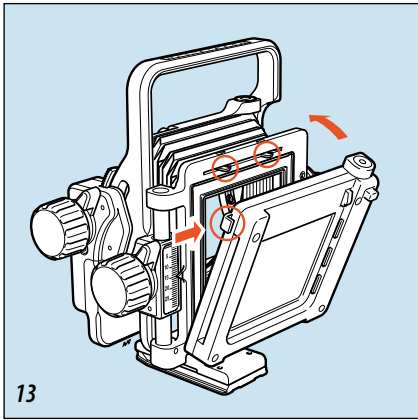

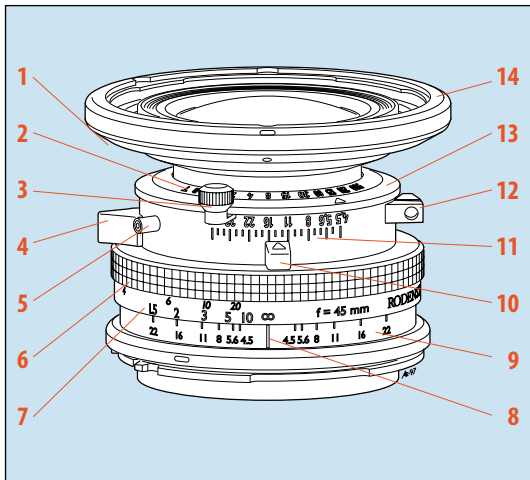

17

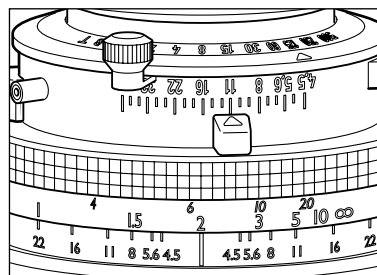

18

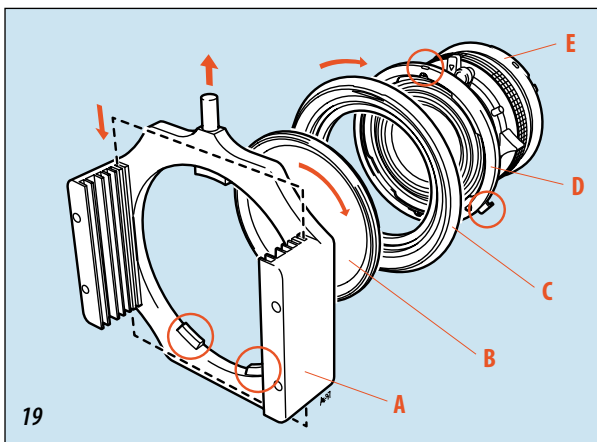

19

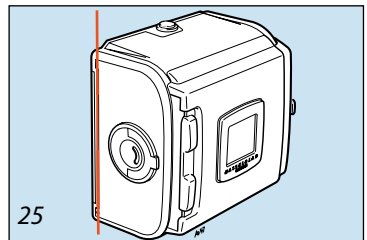
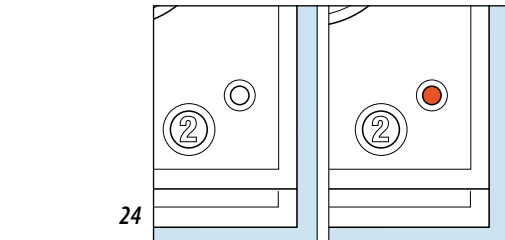
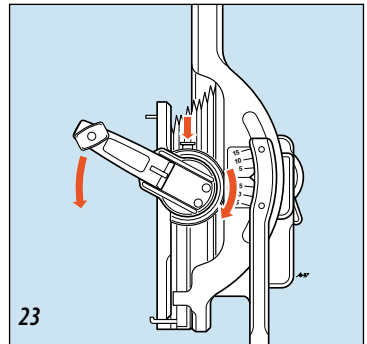
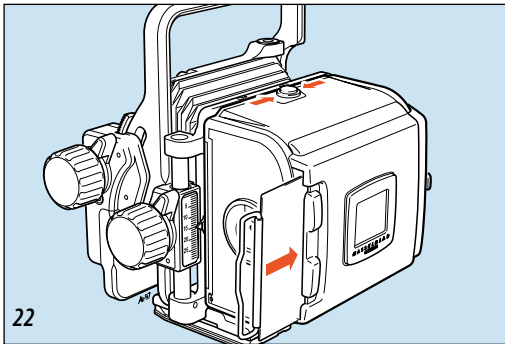
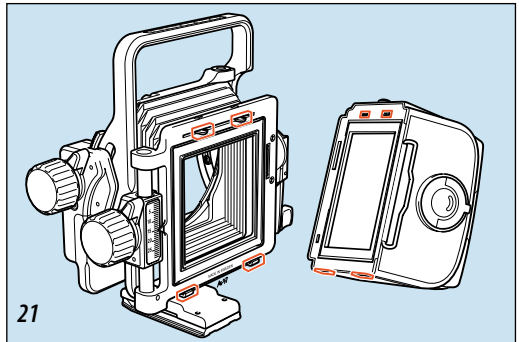
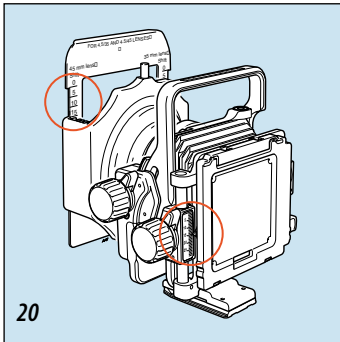

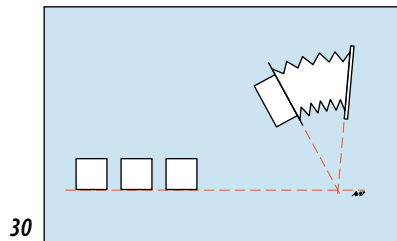
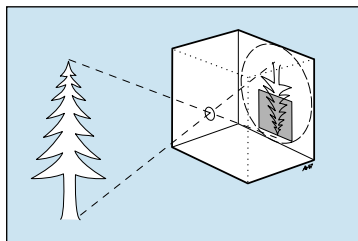
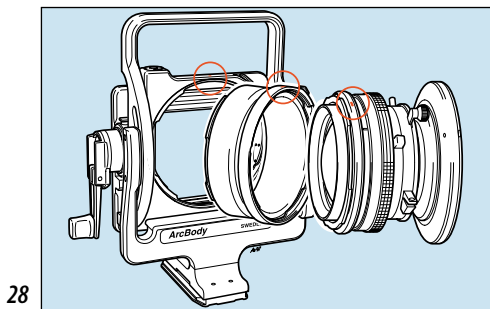
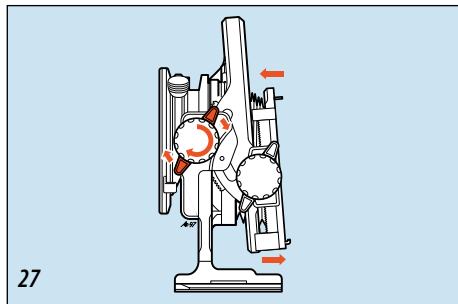
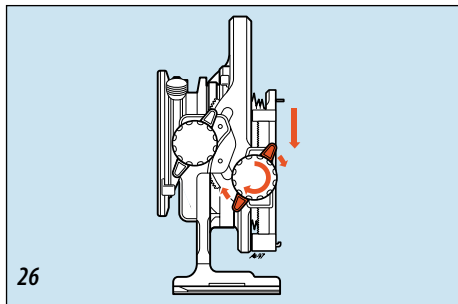

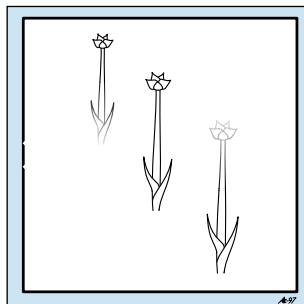
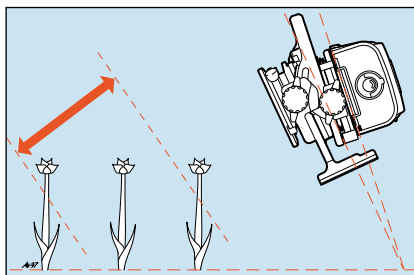
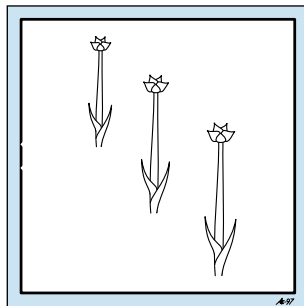
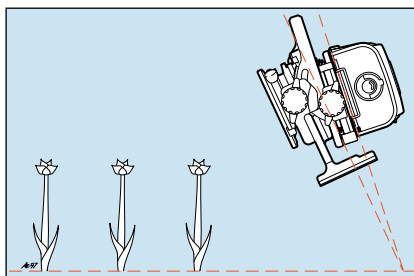
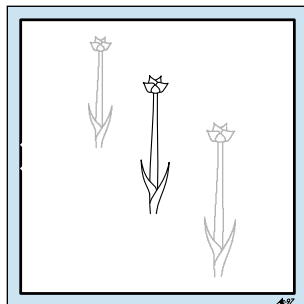
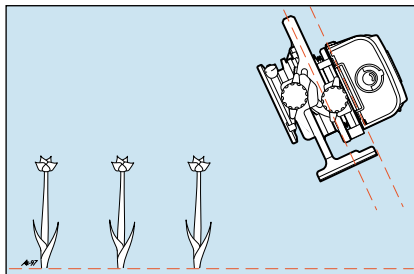

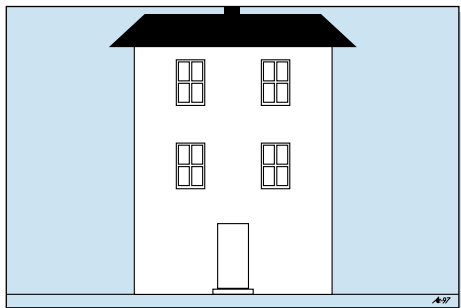
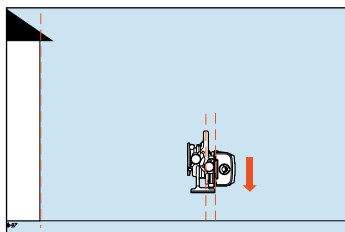
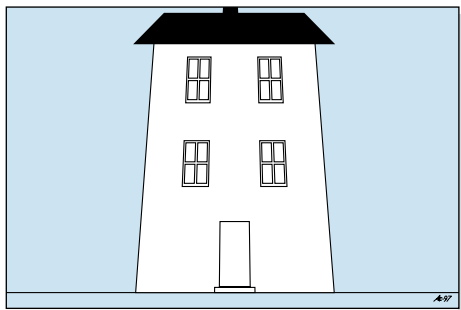
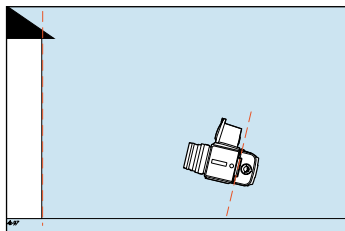
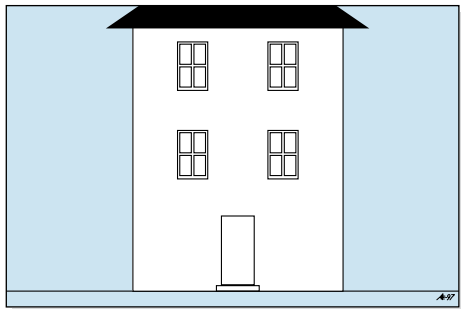
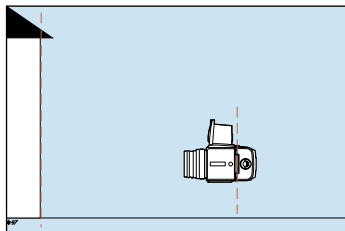

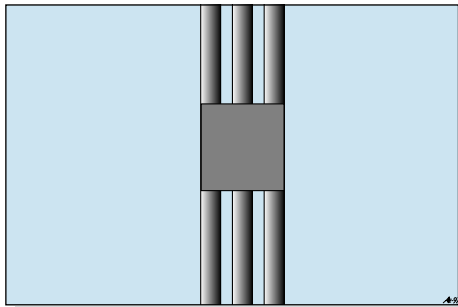
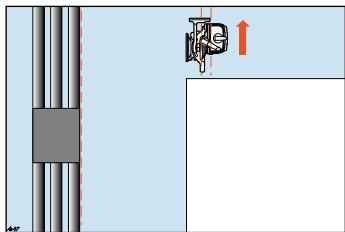
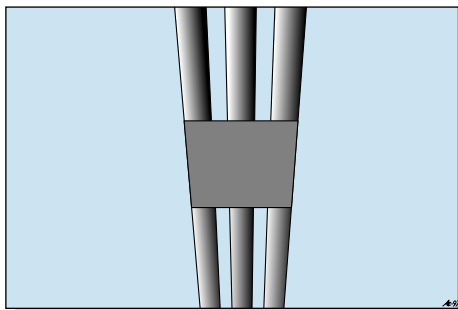
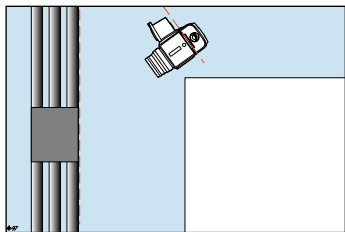
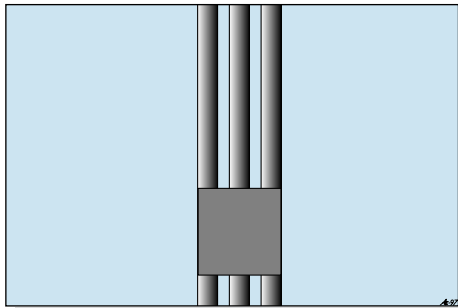
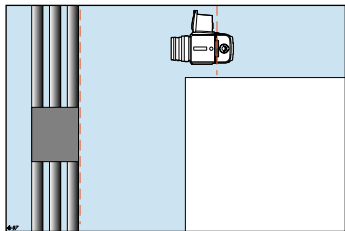

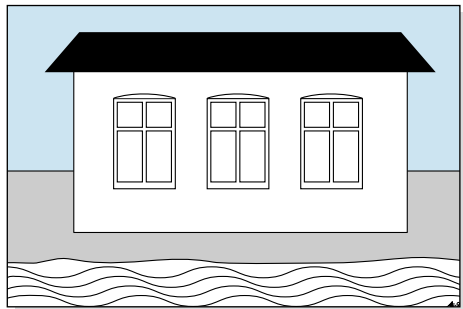
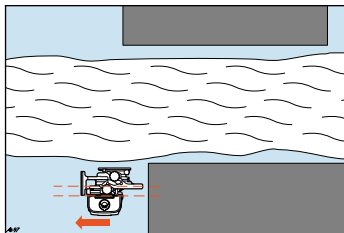
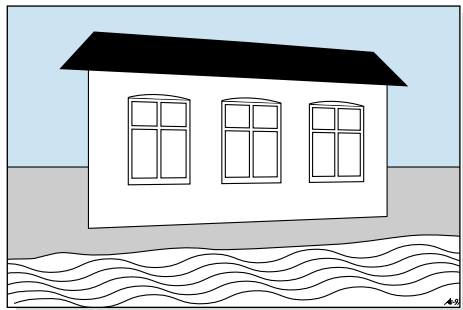
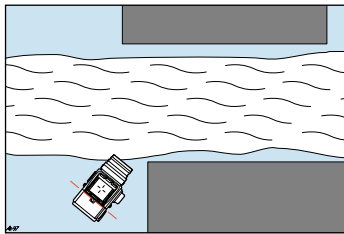
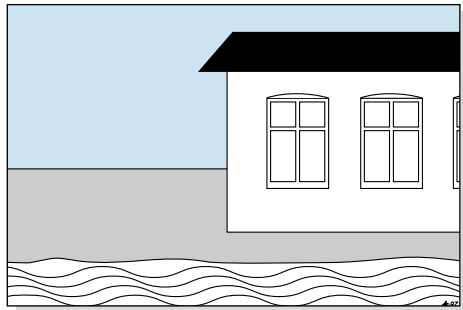
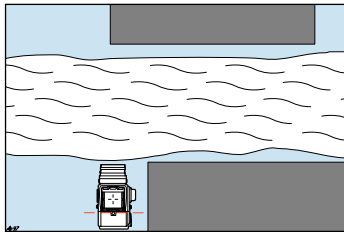

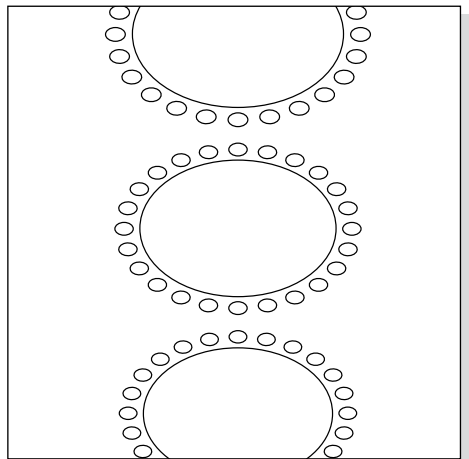
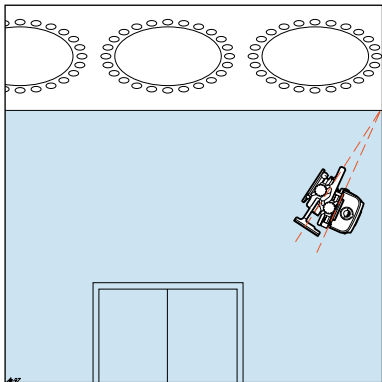
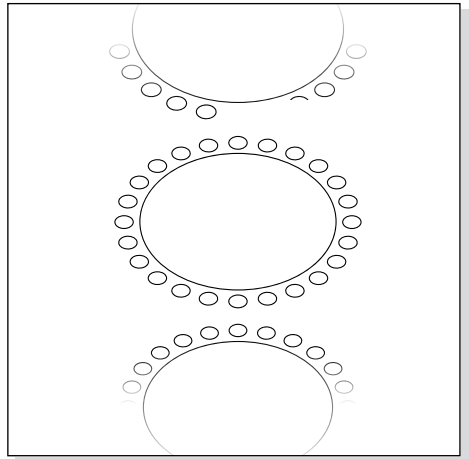
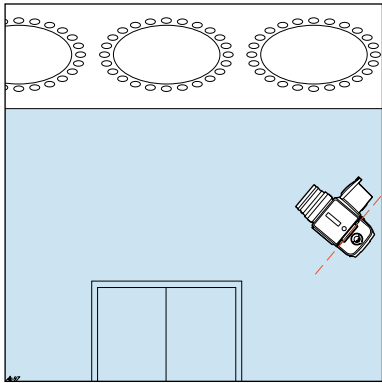

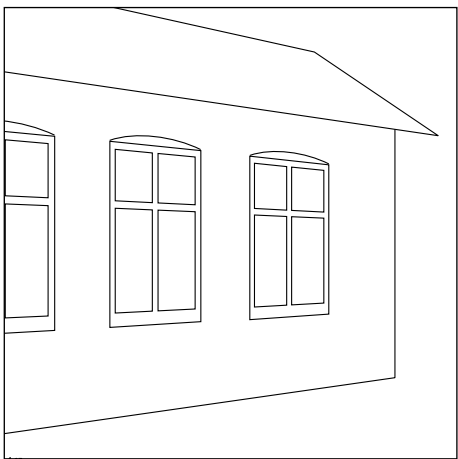
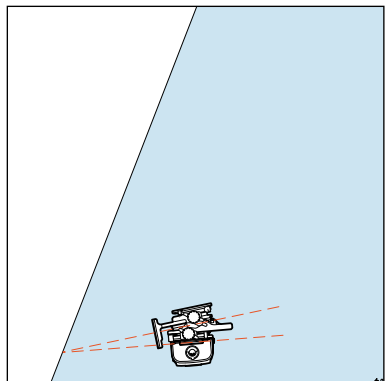
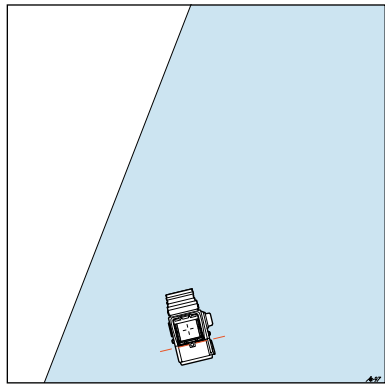

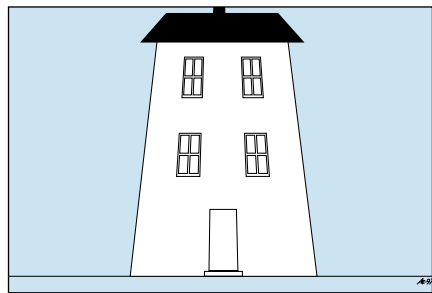
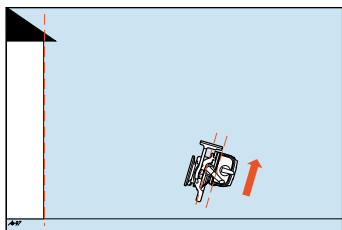
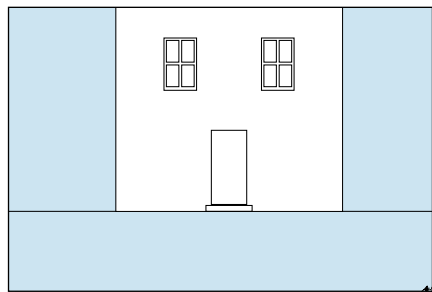
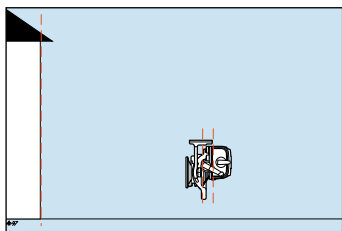
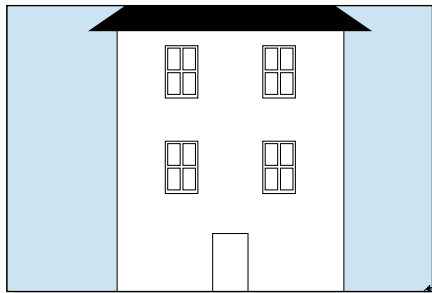
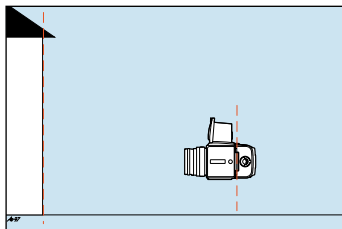

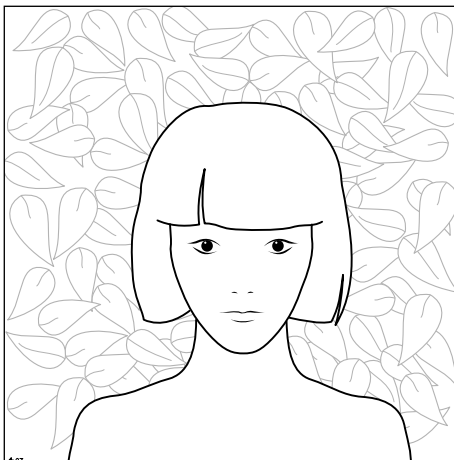
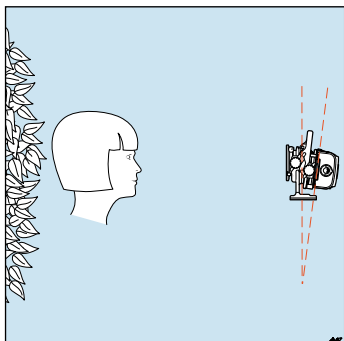
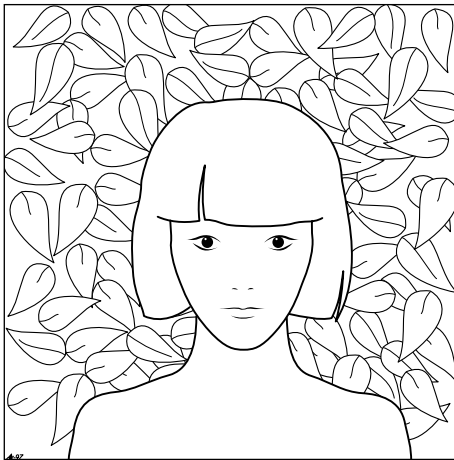
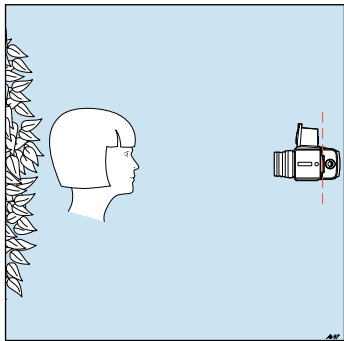

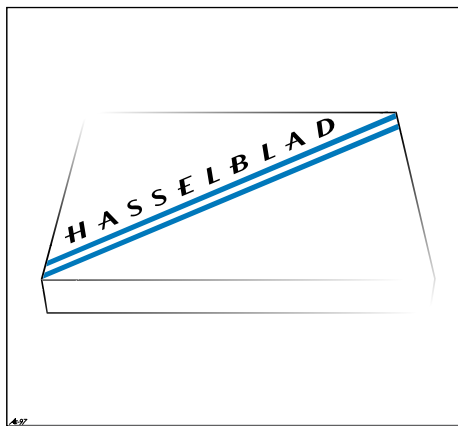
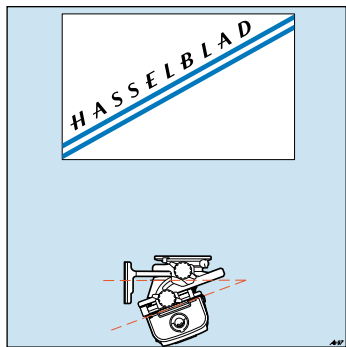
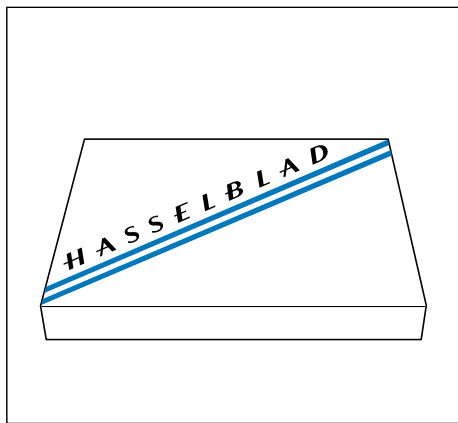
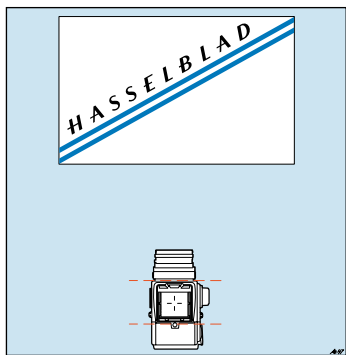

CU	B		
	A	4.5/35	4.5/45
–	0 – 0.10	0 – 0.17	0 – 0.11
8	0.2 – 0.32	0.17 – 0.35	0.11 – 0.21
16	0.44 – 0.54	0.35 – 0.52	0.21 – 0.32
26	0.73 – 0.83	0.57 – 0.75	0.35 – 0.46

CU	B		
	A	4.5/35	4.5/45
PM 51	+0.5	0	0
PME 90 integral	+0.5	0	0
PME 90 Spot	+0.5	0	0

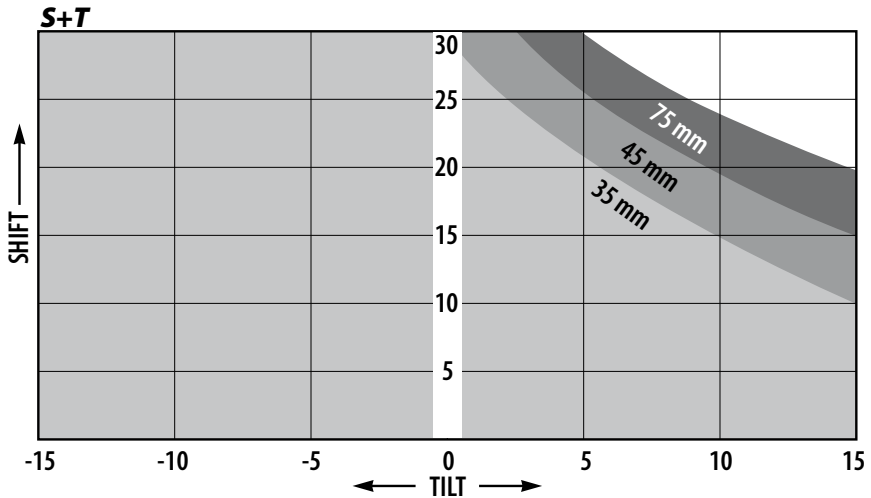

Parts & Components

1 – 2

1. Lens alignment index
2. Spirit level
3. Film winding crank lock
4. Film winding crank
5. Spirit level
6. Tilt scale
7. Tilt control lock
8. Tilt control
9. Lens release catch
10. Shift control lock
11. Shift control
12. Shift scale
13. Spirit level
14. Quick-coupling plate
15. Magazine supports
16. Stray light mask
17. Rear standard
18. Magazine hooks

In the text, positions of components and orientation are described in relation to the camera as seen when taking a photograph, i.e. the lens at the front and viewfinder at the rear.

The figures beside the small headings in the text refer to the appropriate illustrations in the accompanying illustration manual.

ArcBody and Supplied Accessories

The Hasselblad ArcBody camera and lenses are available in a variety of combinations and therefore the accessories that are supplied vary accordingly. Figs. 3,4 illustrate the accessories that are compatible with the ArcBody. These include accessories specific to the ArcBody system and items from the standard Hasselblad system. The following lists these combinations and then describes the function of each item where relevant. Check them against the illustrations and familiarise yourself with each item.

Hasselblad ArcBody complete - 17015

The Hasselblad ArcBody complete is supplied as a package and includes the following accessories:

- 41057 Focusing screen adapter standard
- 47003 Correction slide – S (small).
- 47007 Correction slide – M (medium).
- 47011 Correction slide – L (large).
- 57689 Cable release
- 57695 Filter holder
- 47018 Centre filter holder
- 47024 Lens shade 35/45
- 72422 Stray light mask
- 51070 Rear cover MultiControl

57692 Front cover ArcBody

58480 Carrying case

Hasselblad ArcBody Kit - 17511

The Hasselblad ArcBody kit consists of the Hasselblad ArcBody complete - 17015 package as listed above, plus the following:

27045 Rodenstock Apo-Grandagon 4.5/45 mm

47057 Centre filter

47070 Reflex viewfinder RMfx

27035 Rodenstock Apo-Grandagon 4.5/35 mm

including 57692 Front cover ArcBody and 50571 rear lens cap.

27045 Rodenstock Apo-Grandagon 4.5/45 mm

including 57692 Front cover ArcBody and 50377 rear lens cap.

27075 Rodenstock Grandagon-N 4.5/75 mm

including 57692 Front cover ArcBody and 50377 rear lens cap, plus:

47027 Lens shade 75

47049 Extension tube 26 ArcBody

72411 Stray light protection slide

72413 Correction slide 10°

72415 Correction slide 20°

Optional accessories:

47033 Camera inverter mount

47040 Extension tube 8 ArcBody

47045 Extension tube 16 ArcBody

47049 Extension tube 26 ArcBody

47057 Centre filter

47070 Reflex viewfinder RMfx

Accessory description

41057 Focusing screen adapter standard. This device not only provides the viewing system but also serves as a holder for the correction slides and viewfinders.

47003 Correction slide small. Used to improve image brightness when shift adjustment is no greater than ca. 5 mm.

47007 Correction slide medium. Used to improve image brightness when shift adjustment is ca. 5 – 15 mm.

47011 Correction slide large. Used to improve image brightness when shift adjustment is greater than 15 mm.

47018 Centre filter holder. Specific filter holder for lens centre filter.

47024 Lens shade 35/45. Specially designed lens shade for the 35 mm and 45 mm lenses.

47033 Camera inverter mount. Simply and quickly allows ArcBody to be mounted upside down via an integral Tripod quick-coupling S attachment without resorting to any change in tripod configuration.

- 47040 Extension tube 8 ArcBody. For close-up photography.
- 47045 Extension tube 16 ArcBody. For close-up photography.
- 47049 Extension tube 26 ArcBody. For close-up photography. Supplied as standard with the Rodenstock Grandagon-N 4.5/75 mm.
- 47057 Centre filter. A centrally graduated filter to neutralise coverage.
- 51070 Rear cover MultiControl. Rear protective cover for camera body.
- 57689 Cable release. There is no release button on the ArcBody. The cable release provides a smooth and vibration free action when making an exposure.
- 57692 Front cover ArcBody. For camera body and Rodenstock lenses.
- 57695 Filter holder. General multi-compartment filter holder for all types of M77 standard filters, both 100x100 mm and 100x150 mm. Special fitting for rapid attachment and removal.
- 58480 Carrying case. Compartmentalised to facilitate storage and rapid access.
- 72422 Stray light protection mask. Prevents stray light problems when camera movements are near maximum.
- 72530 The reflex viewfinder RMfx is the recommended viewfinder for general work providing a vertically correct image and a comfortable working position.

Rodenstock Grandagon-N 4.5/75 mm only:

- 72411 Stray light protection slide. Used when no correction slide is in position.
- 72413 Correction slide 10°. Used to improve image brightness when tilt adjustment is no greater than ca. 10°.
- 72415 Correction slide 20°. Used to improve image brightness when tilt adjustment is greater than ca. 10°.

Getting Started

This chapter deals with getting to know the various items in your equipment, their fitting and function. The ArcBody is supplied with a front protective cover and a Rear cover MultiControl. When storing the ArcBody without lens or focusing screen adapter it is advisable to keep the covers in place for protection. Set up the ArcBody on a tripod or camera stand and proceed as follows:

Front protective cover **5**

Turn the cover (bayonet fitting) in the direction of the arrow in the illustration, and lift it out. To avoid leaving the camera body unprotected, do not remove the cover until you are ready to attach a lens. Reattach by fitting and turning clockwise.

Rear cover MultiControl **6**

While depressing the top section, tilt the cover backwards, and lift it off. To avoid leaving the camera body unprotected, do not remove the cover until you are ready to attach the focusing screen adapter or a magazine.

Attaching a lens **7**

Align the red index on the lens with the index on the camera body as in the illustration and allow it to drop into the bayonet fitting. Rotate it clockwise until it stops with a faint click as the lens catch locks it into place.



Only Rodenstock lenses with a Hasselblad bayonet fitting can be used with the ArcBody.



Always use an ArcBody camera and lens front protective cover (57692) with Rodenstock lenses and not conventional Hasselblad front protective covers.

Removing a lens

Depress the lens release catch and rotate the lens counter-clockwise until it stops and lift it out of the mount.

The Viewing System

The focusing screen adapter & correction slides **8 – 12**

The ArcBody employs a removable focusing screen system. In the case of the Rodenstock Apo-Grandagon 4.5/35, and Rodenstock Apo-Grandagon 4.5/45, this consists of a focusing screen adapter and three correction slides. The Rodenstock Grandagon-N 4.5/75 uses two different correction slides and a stray light protection slide. The Acute-Matte D focusing screen, standard

on all Hasselblad equipment, is an innovation in image brightness and clarity, even in poor light conditions. These effects are naturally slightly diminished when shift or tilt are applied as they depend on the film plane remaining parallel to the lens plane and in line with the lens axis. Correction slides are supplied which simply and rapidly return the image to virtually the original quality. They are easy to fit and extend the working range of the Hasselblad ArcBody even further.

In fig. 8 you can see that when the image plane is parallel with the lens plane and in line with the lens axis then full effect is achieved and a bright, clear image is produced.

In figs. 9,10 movements – shift and tilt respectively – without correction slides create loss in image brightness as the light rays are not in line with the viewing axis.

Figs. 11,12 demonstrates that when the correction slides are in position, the light rays are re-directed towards the eye axis and therefore cause a return in full image brightness.

The image is composed on the focusing screen, with or without a hood or reflex viewfinder. The focusing screen adapter is removed and exchanged for a Hasselblad film magazine for exposure.

The focusing screen adapter **13**

Rest the focusing screen adapter on the ArcBody's magazine supports ensuring that it is properly located. Carefully swing it towards the ArcBody, checking that the upper support hooks on the cam-

era body fit into the slots in the adapter. Push it against the hooks while depressing the focusing screen adapter release catch.

To remove, depress the focusing screen adapter release catch and swing the top of the adapter back away from the camera body while lifting it off the lower supports.

Fitting correction slides **14, 15**

Correction slides are chosen and inserted according to the lens and movements used. The basic difference is that the 4.5/35 mm and 4.5/45 mm lenses use the Small, Medium and Large correction slides exclusively whereas the 4.5/75 mm lens uses the 10° and 20° correction slides exclusively.

As each combination of lens/amount of movement/direction of movement differs in requirements, it is not possible to mention every eventuality. There will always be cases where these requirements overlap so a general understanding of the system provides a better basis for correction screen choice.

Correction screens provide an improvement in the image as seen on the focusing screen; they have no effect on the image on the film plane. This means there is no risk involved in using the 'wrong' screen or using a screen the 'wrong' way.

The screens are simply inserted into the slot in the focusing screen adapter, only one screen at a time being used. They may be inserted from the left or the right but always so that the text can be read when viewed from a position behind the camera, fig 14. Look at the lists below for a starting point

and then experiment. The Small, Medium and Large screens work by refracting light rays upwards, while 10° and 20° correction screens work by refracting light rays downwards. Refer back to figs. 8 –12 for an illustration of the effects. A downward shift requires the light to be refracted upwards. A positive tilt requires the light to be refracted downwards. A combination of the two however may create another situation which requires another solution. Of course when the camera is turned on its side or inverted then the screens must also be inserted at 90° or 180° to follow the underlying principles. As an example, fig. 15 demonstrates two camera set-ups requiring different solutions.

Remember to handle and store the screens with care.

(General rules for 4.5/35 mm and 4.5/45 mm lenses only)

Correction slide– SMALL

For use when the amount of shift is no greater than ca. 5 mm.

Correction slide– MEDIUM

For use when the amount of shift is no greater than ca. 5 – 15 mm.

Correction slide– LARGE

For use when the amount of shift is greater than ca. 15 mm.

These lenses require that one of the screens should be in place at all times.

(General rules for 4.5/75 mm only)

Correction slide 10°

For use with moderate amounts of shift and tilt.

Correction slide 20°

For use with large amounts of shift and tilt.

This lens does not need any correction slide with small amounts of movement.



In all cases, insert the correction screens with the inscription visible when viewed from behind the camera.

Stray light protection slide (N 4.5/75 only)

When no movements are used and therefore no correction slide fitted, then the stray light protection slide should be fitted to ensure a clear image. It is inserted in the slot in the focusing screen adapter, either from the left or from the right.

Viewfinders

16

All viewfinders in the Hasselblad system will fit the focusing screen adapter. They are simply slid down into position for attachment and upwards for removal when the ArcBody is in the normal position. They are automatically secured in place by a catch on the focusing screen adapter that must be depressed for removal. An additional -1 dioptre correction is recommended when a standard Hasselblad focusing hood is used. The recommended reflex viewfinder for the ArcBody is the Hasselblad reflex viewfinder RMfx (72530) that provides both a vertically correct image and a comfortable working position. As it can be fitted 'in-

verted' it also works equally well when the ArcBody is inverted via the Camera inverter mount (47033) or otherwise.

Light metering with a Prism meter viewfinder PME51/PME90

The prism meter viewfinders PME51 (incl. earlier models) and the PME90 can be used for light measurement when attached to the focusing screen adapter. Proceed as follows:

1. Set shift and tilt controls to zero as accurately as possible.
2. Remove centre filter
3. Insert a correction slide 'Small' when using a 35 mm and 45 mm lenses, or a stray light protection slide when using a 75 mm lens.

As the prism meters were designed for use with standard Hasselblad cameras, slight adjustments should be made to the exposure reading when fitted to an ArcBody according to the table 'PM' at the end of the illustration booklet. Column A represents the prism meter type or mode while column B represents the lens types and the amount of adjustment in EV required.

Lenses

With the lens and the focusing screen adapter attached to the ArcBody, the combination becomes a complete camera. As there is no mirror, the ArcBody behaves in the same manner as a view camera in the sense that a direct inverted image is formed on the focusing screen and that the focusing screen has to be exchanged for a film magazine for exposure.

There are three lenses to choose from that fit the ArcBody: the Rodenstock Apo-Grandagon 4.5/35, the Rodenstock Apo-Grandagon 4.5/45 and the Rodenstock Grandagon-N 4.5/75. The latter two lenses have a similar appearance and are operated in the same manner. The Apo-Grandagon 4.5/35 has slight differences in both appearance and operation that are mentioned separately below. Fig.17 illustrates the features of the Apo-Grandagon 4.5/45.

Apo-Grandagon 4.5/45

17

1. Release catch
2. Shutter speed scale
3. Shutter winding lever
4. Open/close shutter lever
5. Flash sync terminal
6. Focusing ring
7. Focusing scale
8. Central lens index
9. Depth-of-field scale
10. Aperture lever
11. Aperture scale

12. Cable release port
13. Shutter speed ring
14. Accessory mount

Apo-Grandagon 4.5/35 mm

The compactness of the Apo-Grandagon 4.5/35 requires slight differences in design and operation which are as follows:

- a. The focusing ring has an extension in the form of a lever to facilitate adjustment.
- b. The open/close shutter lever has an extension to facilitate access.
- c. The lens must be attached and removed without the cable release in position.

Grandagon - N 4.5/75 mm

Although removable, the Extension tube 26 ArcBody is intended to be an integral part of the Grandagon - N 4.5/75 and must always be attached to the lens when in use.

Lens operation is as follows:

Fit the lens to the camera body as already described.

Viewing: Open and close the lens by moving the open/close shutter lever.

Focus: Focus the lens by rotating the focusing ring until you obtain a sharp image of the subject in the viewfinder. The distance between the subject and the film plane is read off the focusing ring's distance scale opposite the central lens index.

Shutter: To set the shutter speed, rotate the shutter speed ring until the red index mark is aligned with the desired speed.

Aperture: Move the aperture ring until it aligns with the desired position on the aperture scale.

Depth-of-field: Objects closer or farther away than the selected focusing distance may also be rendered sharp, within specific limits. The limits of this field of sharp focus – the depth-of-field – vary according to the aperture size and focus setting. This field can be visually checked on the focusing screen when the desired aperture has been selected, or read off the depth-of-field scale on the lens.

The depth-of-field available at any given aperture setting can be read off the focusing scale opposite the appropriate marks on the depth-of-field scale on both sides of the central index. As an example, fig. 18 indicates how to read the depth-of-field scale at an aperture of $f/11$ and a focus setting of ca. 2 m (ca. 6.5 ft). This combination would provide a zone of acceptable sharpness stretching from ca. 1.4 m (ca. 4.5 ft) to ca. 5 m (ca. 16.5 ft)

Flash synchronization: Attach cord from flash unit to the flash sync terminal. There is flash synchronization at all shutter speeds.



To ensure the brightest possible viewfinder image, remove all filters.



Do not forget to stop down to the desired aperture setting before exposure.



Do not remove the slide from an attached magazine before you have closed the shutter (open/close shutter lever).



When using large amounts of shift with the 35 mm or 45 mm lenses, stop down to f/16 or beyond to ensure even illumination.

Filter holder

19

To maintain the brightness on the focusing screen while focusing and composing, it is easier to add any filtration required just before exposure. To facilitate this operation as well as simplify general use, both the centre filter, additional filters and lens shades can be attached and removed as a combined unit. This produces a very rapid and convenient way of working.

The lens (e) has an accessory mount (d) (bayonet fitting) that holds the centre filter holder (c). The centre filter holder has a screw fitting to hold the circular centre filter (b) as well as a surrounding flange to hold the filter holder (a). Together (a),(b) and (c) combine to produce the removable filter holder assembly.

The filter holder is a Lee type so there are several compartments to accommodate not only different thicknesses and types, but also several filters simultaneously. All standard 100x100 mm and 100x150 mm filters will fit and can be adjusted vertically, for example, if graduated filters are used.

By pulling the knob on the filter holder catch tem-

porarily, the holder can also be oriented at a 90° click-stop position, or freely at any angle in the vertical plane.



A deviation from the vertical orientation of the filter holder may affect the performance of the lens shade causing slight vignetting and so should be checked accordingly.

Attaching the filter holder assembly:

1. With the lens in place, align the index marks on the centre filter holder and lens surround and rotate the filter holder clockwise until it clicks into place.
2. Screw the M77 centre filter into place in the centre filter holder.
3. Ensure the two lower lugs on the filter holder are seated properly in the protruding rim of the centre filter holder. While lifting the knob of the filter holder catch, gently push the whole assembly into place, releasing the knob so that the catch is positioned in the slot in the centre filter holder.

Removing the filter holder assembly.

Press the catch on the lens accessory mount while rotating the filter holder assembly counter clockwise. To remove the filter holder only, leaving the centre filter in position, pull the knob of the filter holder catch upwards and pull the filter assembly away from the lens.

In this way, all the accessories can be removed and

replaced as one unit, very rapidly and without any need for further adjustment. An accessory pouch that can be attached to a belt is available to temporarily store the combined filter unit while final adjustments are made. This may be more convenient than finding a clean and stable surface to rest it on when on location.

The centre filter

The centre filter should be used at all times with the 35 mm and the 45 mm lenses. It neutralises the light fall-off naturally inherent in wide-angle lenses of this kind and so produces an even light coverage over the film plane. Its use is also recommended with the 75 mm lens when maximum shift is being used.

Another M77 filter can be fitted instead of, or as well as, the centre filter for special effects. However, an additional filter screwed onto the centre filter will cause some vignetting.



If you remove the centre filter to improve image brightness in the viewfinder, do not forget to replace it.



Do not forget to increase the exposure by 2 EV if the centre filter is used.

Lens shade adjustment

20

The front compartment is reserved for the lens shade. This is placed in the holder so that the engraved scales are visible from a position behind the camera. When shift is used, the amount is read off the shift scale on the camera body and this amount is trans-

ferred to the relevant scale on the lens shade. Do this by sliding the shade upwards to align with the index correctly. This ensures that the correct amount of shading is provided according to the amount of shift applied. Make sure you use the correct scale on the shade according to the lens in use.

Film Magazines

All Hasselblad film magazines are compatible with the ArcBody, thus providing you with a wide choice. 6x6 cm and 6x4.5 cm formats are catered for, 120, 220 and 70 mm perforated film types as well as Polaroid type instant films. See respective instruction manuals for operational details. (Certain aspects of the following working procedure do not apply to Polaroid, Pola Basic/Plus magazines, see relevant Polaroid manuals)

Attaching a magazine

21, 22

Ensure that the magazine status indicator is white. If the indicator is red then see section below.

After removing the focusing screen adapter, rest the magazine on the magazine supports making sure that they are properly engaged in the recesses on the underside of the magazine. Carefully swing the magazine towards the camera body and check that the camera's upper support hooks fit into the slots in the magazine.

Push the magazine gently but firmly against the hooks while sliding the magazine catch button to the right. Release the button when the magazine

has made contact with the camera body, and then push the button to the left to ensure that it has reached the locked position. Remove the slide so that the magazine positively locks onto the camera body. The camera is now ready to use.

Magazine slide holder **22**

All recent film magazines have a slide holder on the back that stores the slide when not in use. Insert it, with the grip facing the rear of the magazine, folding the grip into place over the protrusions.

Film advance **23**

After exposure, initially press the film winding crank lock (a) to free the crank. Rotate crank by one full revolution. The handle can be folded out or remain folded away in cramped situations. The crank has a ratchet drive so it can be 'pumped' with small movements if it is easier to do so. One full rotation will advance the film by one frame and will automatically lock at the correct position, regardless of format. Naturally, a multiple exposure requires that the film be advanced only after the final exposure.

Removing a magazine

After advancing the film one frame, insert the magazine slide fully. Slide the magazine catch to the right, swing the magazine back and lift it off the lower supports.

The magazine status indicator **24**

The status indicator on the right hand side of the magazine shows white when the magazine is ready to operate and red when the film has not been advanced after an exposure. If the status indicator shows red, attach the magazine to the camera and advance it one frame by turning the film winding crank one complete revolution.

Film plane position **25**

The red line in the illustration marks the location on the film magazines that coincides with the film plane position.

ArcBody Movements

The Hasselblad ArcBody has two camera movement controls – shift and tilt. It is these two movements that the ArcBody utilises to exercise control over image shape and sharpness.

The amount of movement needed varies according to the desired effect, there is no formula and each case must be judged accordingly by what is seen on the focusing screen. Certain restrictions apply however regarding the possibility of vignetting. Normally this is immediately apparent in the viewfinder and you would therefore take the appropriate steps to make corrections. If you prefer, the diagram 'S+T' at the end of the illustration booklet provides a secure and convenient method of checking. The vertical axis represents the amount of shift in millimetres while the horizontal axis represents various amounts of tilt in degrees. The shaded areas represent vignette free shift and tilt combinations.

Cross reference the amount of shift in millimetres with the amount of tilt in degrees applied to see whether vignetting is likely to occur. The diagram assumes the lens is focused at infinity and the aperture set at $f/16$ and positive tilt occurs when the top of the rear standard is tilted away from the lens when the camera is in the upright position.

Example: When using a 35 mm lens, the rear standard is shifted 15 mm and tilted $+7^\circ$ without problem. When the shift is increased to 20 mm

while maintaining the $+7^\circ$ tilt, vignetting occurs. Vignetting caused by accessories should be checked separately.



Certain combinations of shift and tilt are not possible owing to the constraints of the bellows. Try to find a compromise combination instead.

See later section on camera movements in practice and their effect on the image.

Shift

26

To lower the camera back, loosen the red shift control locking levers (clockwise) and rotate the shift control clockwise. Use the appropriate correction slide (see relevant section), if necessary, to improve the brightness of the image. The amount of shift can be read off the shift scale.

The back can be shifted downward approximately 28 mm from the zero position. To produce the opposite result, namely to shift the back in an upward direction from the zero position, then simply invert the camera using the 47033 Camera inverter mount.

Tilt

27

The camera back is tilted by loosening the red tilt control knob locking levers (clockwise) and then rotating the tilt control. A clockwise movement of the control causes the top of the rear standard to move towards the lens and the bottom of the rear standard to move away from the lens. Rotating the control in a counter-clockwise manner will produce the opposite result. The tilt scale displays how much tilt has been

put into effect, approximately $\pm 15^\circ$ being possible. Use a correction slide, if necessary, to improve the brightness of the image.

Close-up photography **28**

When the camera is very close to the subject, sufficient sharpness may not be produced. This can be corrected by fitting the appropriate extension tubes. They fit between the lens and the camera body and are attached and removed in the same manner as lenses. However, the focus and depth-of-field scales on the lens will then not apply, so a visual check must be made on the focusing screen.

Choice of tube can simply be determined by experimentation or by checking the table 'CU' at the end of the illustration booklet that illustrates the extension tube/lens /magnification ratio possibilities. The column to the left (A) denotes the extension tube while the horizontal heading (B) refers to the image scale range for each lens in three separate columns. Look up the amount of magnification required under the correct lens heading to read off which extension tube should be used.

Example. To produce an image $1/4$ original size (image scale 0.25) you could combine:

- 4.5/35 lens + 8 mm extension tube
- 4.5/45 lens + 8 mm extension tube
- 4.5/75 lens + 16 mm extension tube

If you combine two or more extension tubes, position the shortest tube closest to the lens to minimize vignetting problems when shift is used.

Use the minimal amount of shift with close-up photography. This will then allow a greater amount

of tilt to be used without vignetting problems.

When you add a 26 mm extension tube or combination of tubes that includes a 26 mm to a 35 mm or 45 mm lens, the use of a Correction slide 10° or a Correction slide 20° to improve image brightness in the viewfinder is recommended.

Bellows

The bellows is made of natural fabric and is designed to permit a combination of shift and tilt movements.

However a combination of near maximum settings should be avoided as this may cause the bellows to distort. It is also advisable to keep the bellows stored at the 'neutral' (10 mm shift) position when not in use.

Exposure sequence

The ArcBody is a very simple camera to operate, however, to avoid errors it is advised that you try to adopt a specific routine that you always follow.

1. After setting up the ArcBody complete with lens and focusing screen adapter on a tripod or stand, set tilt and shift controls to zero.
2. Adjust the camera position using one of the integral spirit levels. This ensures that the back is vertical and simplifies the need for further adjustments when working with architectural perspective control, for example.
3. Screw the cable release into the cable release port..
4. Push the open/close shutter lever to open the shutter and obtain an image on the focusing screen.

5. Compose the photograph. Focus the camera by turning the lens barrel. A distance scale and depth-of-field scale are engraved on the lens to provide a rough guide and are sufficient for general practice but of course the use of the focusing screen is advised for accurate work. Stop down to the chosen working aperture.
6. Make necessary shift or tilt adjustments. Insert suitable correction slide if required. Carefully check the image for both image shape, depth-of-field and any possible vignetting. Adjust focus accordingly if necessary but remember it is much easier to check the focus with little or no shift used.
7. Lock shift and tilt controls.
8. Ensure that the centre filter is in place if required and attach filter holder with lens shade and other filter if required.
9. Check that adjustment of lens shade is in accordance with shift amount, if necessary.
10. Make final check for vignetting, particularly if a combination of shift and tilt movements are used.
11. Close the shutter with the open/close lever, set the chosen shutter speed and aperture settings and wind the shutter. If the centre filter is in position, increase the exposure by 2 EV.
12. Remove the focusing screen adapter.
13. Ensure that the film magazine indicator is white. If the indicator is red, the magazine will have to be wound one full revolution after it has been attached to the camera unless you are going to make a multiple exposure.
14. Rest the magazine on the magazine supports, ensuring it is properly located on them. Carefully swing the magazine toward the camera body and check that the camera's upper support hooks fit into the slots in the magazine. Push the magazine gently but firmly against the hooks while pushing the magazine catch to the right.
15. Release the catch when the magazine has made contact with the rear standard, and push it to the left to ensure that it has reached the locked position.
16. Remove the magazine slide.
17. Make the exposure by pressing the cable release.
18. Insert the magazine slide fully.
19. Advance the film.
20. Push the magazine catch to the right, swing the magazine back and lift it off the lower supports.

You may of course prefer to alter the order of some of the above, but there are some major points you should always remember:



Ensure that the shutter is in the closed position before you withdraw the slide from an attached magazine.



Do not forget to remove the magazine slide before exposure.



Do not forget to replace the slide before you remove the magazine.



Advance the film after exposure (unless you are making a multiple exposure).

Failure to observe any of these points will result in lost exposures!

Camera Movements in Practice

Shift and tilt, familiar terms to technical camera users, quickly become second nature to Hasselblad ArcBody photographers too. A few minutes thought over the examples shown here will help to explain the ideas behind the method.

Shift simply moves the film plane through the plane of a projected image and places it where most suited for that particular image. As an exaggerated demonstration, imagine the camera image as a projected image on a wall in a darkened room fig. 29. Move a square of paper – the film – over the wall until you have the desired framing and that, in essence, is shift. So, while the lens and image plane remain parallel to a building, for example, you can place the film over the area that is showing the top of a building without resorting to pointing the camera upwards, which would cause convergence of verticals in the image. This extremely useful cor-

rective effect is facilitated by the unusually large circle of coverage created by the Rodenstock lenses.

Tilt is a camera movement that has most effect on the sharpness of the image caused by controlling the depth-of-field. The original principle, determined by Scheimpflug, is demonstrated in fig.30. In this example, the maximum effective depth-of-field is achieved when all three planes meet at one point. Depth-of-field – the zone of an image that is acceptably sharp – is controlled by the aperture setting. The angle of the plane of this zone, however, can be altered to achieve greater sharpness in the image, and that is in effect what tilt produces.

Unsharpness of the near and far limits of an image at a specific aperture/focus setting is caused by insufficient distances between these limits and their respective positions on the film plane, fig 31. The solution to the problem is to alter these distances. In fig. 33 you can see that by tilting the back of the camera, the distance from the top of the film plane to the near limit has now increased. (Remember the image is inverted!) Likewise, the distance of the lower part of the film plane to the far limit has now decreased. Both distances now fall within the zone of acceptable sharpness and the result is an apparent increase in depth-of-field fig.34.

In practice, care must be taken. When the back of the camera is moved in this manner, the plane of sharp focus is angled away from vertical objects. Fig. 35 illustrates this effect. While objects in the image that lie close to the camera are now sharper,

the tops or bottoms of tall objects may now be less sharp because they have now fallen out of the zone, fig.36.

So, more simply described in this example, by tilting the top of the rear standard of the camera backwards, you will get an increase in depth-of-field. Conversely, by tilting the bottom of the rear standard of the camera backwards, you will get a decrease in depth-of-field, each effect being achieved without resorting to a change in aperture. This extremely practical capability is facilitated by the patented bellows on the Hasselblad ArcBody, allowing for a large amount of movement without causing vignetting.

In short, variations in shift and tilt in both the horizontal and vertical planes, separately or together, produce results and effects impossible with conventional medium format camera configurations. Look at the examples here and imagine what kind of images you could produce. Perhaps you have a recurring problem you recognize that could be solved instantly or perhaps you can imagine a creative effect that you have been striving for in your pictures to catch the art director's eye. The Hasselblad ArcBody is a powerful tool that can be considered for a surprisingly large number of assignments, displaying a versatility that is unique in the medium format!

Shift examples

37– 42

1.Problem: You want to photograph the exterior of a tall building. In the conventional placing of camera on a tripod at ground level and fairly close to, the camera has to be pointed upwards if the top of the building is to be included or a wide angle lens has to be used or both. Convergence of the verticals then occurs causing an unnatural effect.

Solution: Mount the ArcBody and level it by checking the integral spirit levels on the camera body and lens mount. Compose as normal and then shift the rear standard downward until you see the desired amount of building included on the focusing screen. The verticals will remain parallel to each other because the rear standard has remained parallel to them.

43– 48

2.Problem: You want to photograph an arrangement of pipes at an industrial site. Your only vantage point is from the top of an adjacent and fairly close building. A problem occurs in that the area of interest is part way down the arrangement so when the camera is tilted downward, the parallel pipes display an unacceptable amount of divergence at the top of the picture.

Solution: The ArcBody is mounted in the inverted 180° position and levelled to ensure the rear standard is parallel to the pipe arrangement. The rear standard is then shifted upwards bringing the desired area into view on the focusing screen while not producing the apparent divergence of the pipes.

3.Problem: You want to photograph the facade of a building across a river. You cannot move your camera position further to the right in order to be square on (to ensure right angles remain so with in window frames, architectural details, etc) as other obstructions are in your way. The right hand side of the building is not visible on the focusing screen but you do not want to point the camera to the right as this would cause convergence and ruin the desired effect.

Solution: Mount the ArcBody at 90° with the 'top' of the camera on your right hand side. Check to see that the rear standard is parallel to the building facade. Compose as normal and shift the rear standard to the left. The right hand side of the building should now be visible on the focusing screen but the film plane remains square on to the facade, therefore no convergence is caused.

The three situations above are essentially identical. The second problem is really the first problem but 'inverted' 180° . The solution is therefore also the same except 'inverted'. The third problem is also the same but this time at a difference of 90° and is accordingly solved by turning the camera 90° . Try to visualize photographic situations such as these in terms of vertical and horizontal planes to determine the appropriate solution.

4.Problem: You want to photograph a garden. It is important that detail is sharp immediately in front of the lens while being just as sharp many metres away. A very small aperture cannot be used and insufficient depth-of-field is achieved, even using a hyperfocal distance setting.

Solution: Set up the ArcBody as normal. With shift set at the zero position, tilt the top of the rear standard away from the camera body and re-compose the image on the focusing screen. Adjust the focus again if necessary. There will be a noticeable increase in depth-of-field without changing the aperture.

5.Problem: You want to photograph a ceiling. The camera has to be positioned at one end of the room and all the details must be rendered sharply. You cannot obtain sufficient depth-of-field from the camera position even though the minimal aperture and hyperfocal setting is used.

Solution: Set up the camera to include as normal. With shift set at the zero position, tilt the bottom of the rear standard away from the camera body and re-compose the image on the focusing screen. Adjust the focus again if necessary. There will be a noticeable increase in depth-of-field.

59–62

6.Problem: You want to photograph the whole length of a wall at an angle. All details on the wall must be rendered sharply. You cannot use a smaller aperture for exposure reasons which in turn creates insufficient depth-of-field.

Solution: Set up the ArcBody at 90°. With shift set at the zero position, tilt the top of the rear standard away from the camera body and re-compose the image on the focusing screen. Adjust the focus again if necessary. There will be a noticeable increase in depth-of-field without resorting to a smaller aperture.

Again, the three situations above are essentially identical. The second problem is really the first problem but 'inverted' 180°, and the third problem at a difference of 90°.

Creative examples of shift and tilt

The photographic situations just mentioned are normally considered as faults that have to be corrected. However the very same visual changes can also be classified as creative additions and can be used to positive effect.

63–68

7.Problem: You want to photograph the front of a building to produce a dramatic effect. You cannot position the camera closer to the building. When pointed upwards, convergence is not as strong as hoped.

Solution: Set up the ArcBody in the inverted 180° position. Shift the rear standard upwards. This

places the foot of the building and some of the foreground onto the focusing screen. Point the camera upwards to regain the original image placement. The parallels in the image will now show a more pronounced converging effect.

69–72

8.Problem: You want to take a portrait against a specific background. This background however is being rendered too sharply and detracts from the main subject, even at maximum aperture.

Solution: Set up the ArcBody as normal. While keeping the lens plane parallel with the main subject, tilt the rear standard (in either direction) and the depth-of-field will be reduced.

73–76

9.Problem: You want a photograph of a package where only the name will show. The name is at a diagonal to the camera position. To render the name sharply, you have to stop down the lens but this creates distracting sharp zones in front and behind the name.

Solution: Set up the ArcBody at 90°. Compose the picture with name centred. Tilt the rear standard (to be parallel to the name). The zone of sharp focus, using a large aperture, will now be at an angle to the camera position and cover the name but not the rest of the package.

A combination of shift and tilt can also cause significant changes in image shape and appearance, either as corrective measures or as creative expres-

sions. There are limitations, however, as each lens has a specific circle of coverage. The Rodenstock lenses for the ArcBody have a large circle and can therefore allow a moderate amount of film plane placement within that circle. Both shift and tilt can be used together to provide a combined effect, bearing in mind the previously mentioned limitations.

While it is not intended that the ArcBody should have all the possible movements that some technical cameras have, you may wish to read relevant articles about camera movements in the photographic literature. They should provide you with a deeper insight into the ideas that lay behind what takes place.

Troubleshooting

Problem	Possible cause / remedy
You cannot remove the lens.	<ul style="list-style-type: none">• Depress lens release button.
There is no image on the focusing screen.	<ul style="list-style-type: none">• Lens cap still in place.• Shutter closed.
You cannot produce a sharp image with the 75mm lens.	<ul style="list-style-type: none">• The 26 mm extension tube is not in place.
Shift or tilt control cannot be moved.	<ul style="list-style-type: none">• Release appropriate locking screws.
The image is dark when the back is shifted/tilted.	<ul style="list-style-type: none">• Insert appropriate correction slide.
The image becomes very unsharp when a correction slide is inserted.	<ul style="list-style-type: none">• Correction slide inserted incorrectly.
The image is dark at one edge or the corners of the focusing screen.	<ul style="list-style-type: none">• Vignetting has occurred.• Centre filter not in place.
Shutter will not fire when cable release is pressed.	<ul style="list-style-type: none">• Shutter has not been cocked.• Open/close shutter lever is open.
Film image shows vignetting.	<ul style="list-style-type: none">• Appropriate steps against vignetting not taken.• Combination of shift and tilt movements excessive.
Film frames have been fogged.	<ul style="list-style-type: none">• Magazine slide removed while shutter still open.• Magazine removed from camera before insertion of slide.• Shutter opened before magazine slide replaced.

Technical Specifications – ArcBody

Body type:	Technical, with a shiftable and tiltable back.
Design:	Mechanical, with controls for tilt and shift.
Film advance:	Manual advance with winding crank.
Tripod coupling:	1/4 " and 3/8 " socket threads and base plate for Hasselblad Tripod quick-coupling attachment.
External dimensions:	60 x 145 x 160 mm (2.4 x 5.7 x 6.3") – LxWxH - body only
Weight:	550 g (1.2 lb).
Focusing screen:	Acute-Matte D* Screen with three correction slides (patent pending)
Back shift / tilt control:	Shift: max. + 28 mm (vertical) Tilt: max. $\pm 15^\circ$ (vertical plane tilt)
Lens extension:	Extension tubes ArcBody 8,16,26
Shutter winding:	Manual
Lenses:	Rodenstock Apo-Grandagon 4.5/35, Rodenstock Apo-Grandagon 4.5/45 and the Rodenstock Grandagon-N 4.5/75.
Film types:	120, 220, 70 mm double perforated film and Polaroid type instant film.
Hasselblad compatibility:	Viewfinders: All Hasselblad prism viewfinders with or without a built-in light meter or magnifying hood. Magazines: All Hasselblad 6x6 cm (2 1/4 x 2 1/4"), 6x4.5 cm (2 1/4 x 15/8") format magazines and Polaroid film backs.

**Acute-Matte D designed by MINOLTA*

Equipment Care, Service and Guarantee

EQUIPMENT CARE

The ArcBody is designed to withstand the rigours of professional use in most environments. To avoid the possibility of damage however, it should be protected from the following:

Extremes of temperature: High temperatures can have an adverse effect on both film and equipment. Try to avoid frequent and severe temperature changes. Be particularly careful in humid environments. Allow the equipment to acclimatize before assembly. Try to ensure the storage conditions in such environments are as dry as possible.

Dust and grit: Take care to prevent dust and grit from getting into your equipment. In coastal areas take measures to protect your equipment from sand and salt water spray. Dust on the lens glass and focusing screen can be removed with a blower brush or very soft lens brush if necessary. Smears on the lens glass should be treated with great caution. In some cases they may be removed with a high quality lens cleaning solution on a tissue but be careful not to scratch the lens or touch any of the glass surfaces with your fingers. If in any doubt, do not attempt to clean lens glass surfaces yourself but allow a "Hasselblad Authorized Service Center" to treat them.

Impact: Your equipment can be damaged by severe physical shocks so practical protective precautions should be taken. The bellows section of the ArcBody is particularly vulnerable to physical

damage and care should be taken near pointed or sharp objects. The ArcBody is best stored with the bellows in the 'neutral' position (10 mm shift and zero tilt). Do not leave correction slides in pockets or elsewhere where they could be damaged.

Loss: Hasselblad equipment is much sought after and you should take obvious steps to prevent theft. Never leave it visible in an unattended car, for example. Separate and specific camera insurance cover should be considered by professional users.

SERVICE

Return your equipment to a service centre for occasional checking and preventive maintenance to ensure optimal reliability. If your camera is used constantly and intensively, periodic check-ups every six months are recommended at one of the "Hasselblad Authorized Service Centers". They have the expert staff and specialised equipment necessary to ensure that your equipment remains in perfect working order.

GUARANTEE

Provided that you bought your equipment from an authorised Hasselblad outlet, it is covered by an international guarantee for one year. The guarantee document and a registration card are supplied with the camera. Keep the guarantee document carefully, but fill in the registration card and return it to your Hasselblad distributor.

NOTES

Product no:

17015, 17511

Hasselblad reserve the right to make changes in the published specifications without prior notice.

All rights reserved. No part of this material may be reproduced, stored in a retrieval system, or transmitted, in any form or by any means, electronic, mechanical, photocopy, recording, or otherwise, without the prior written permission of the company.

Copyright © 1997, Victor Hasselblad AB



H A S S E L B L A D

Victor Hasselblad AB
Box 220, SE-401 23 Göteborg, Sweden
www.hasselblad.com